

FETCO® User's Guide and Operator Instructions

CBS-2231 & CBS-2232 Next Generation Brewing System FETCO Next Generation-NG® Commercial Beverage Equipment



CBS-2231



CBS-2232

(Dispensers not included) (Plastic brew baskets are standard, brewers available with optional stainless steel brew baskets)



CONTACT INFORMATION

FETCO® FOOD EQUIPMENT TECHNOLOGIES COMPANY
600 ROSE ROAD
LAKE ZURICH • IL • 60047-0429 • USA
Product made in USA
INTERNET: www.fetco.com
PATENTS: https://www.fetco.com/pl/pages/patents_74.html
©2020-2024 FOOD EQUIPMENT TECHNOLOGIES COMPANY



fetco.com

PHONE: (800) 338-2699 (US & CANADA)
(847) 719-3000 (All Countries and International)
FAX: (847) 719-3001
EMAIL: sales@fetco.com
orders@fetco.com (to order parts and equipment)
techsupport@fetco.com (all service queries)
P215 REV000 January 2024

COFFEE BREWER CBS-2230NG Series

TABLE OF CONTENTS

Rough-In Drawings	2	Calibration	10
Electrical and Output Specifications	3	Outputs	11
Programming Menu	5	Counters	12
Brew Recipes	5	Brewer Setup	13
Inputs	7	Installation Guide	15
Service	7	Operator Training	16
Hot Water Portions	9	Parts diagrams	18

Specifications and Requirements

FETCO CBS-2230 Brewers have unique construction only available for these models.

Water Requirements:		Coffee Filter Size:	
CBS-2230 20-75 psig, (138-517kPa) 1½ gpm/(5.7 lpm)		13" X 5 or FETCO# F002"	
Optimal water hardness between 125-250 TDS (6-13 grain) Important! Please use a water filter for all beverage equipment		Temperature, as set by factory: 200°F (93°C) inside water tank (at sea level)	
Water inlet fitting: 3/8 inch male flare. Brewer supplied with inlet valve adaptor for BSP to SAE		Electrical: See electrical configuration chart Pg 3.	
Brew Volume: Full Batch 3.8 L/1.0 gal brew			
Brew Capacity (approximate)	CBS-2231 4-8 brews per hour CBS-2232 5-16 brews per hour	Output is controlled by heater power and water temperature	
Total Brew Cycle: Factory setting: 6 minutes consisting of 4 min. brew time and 2.0 min. drip delay Individual menu brew-process parameters are user controllable for: Basic user controls for brew volume, brew time, units of measure, recipe name Advanced user controls for pulse count, prewet percent and prewet delay, drip delay, programmable energy saving See pages 4-5 for how to adjust controls for temperature, brew volume, units - and all other settings			

Weights and Capacities

Model	Height	Width	Depth	Water tank capacity	Empty Weight	Filled Weight	Shipping Weight	Shipping Dimensions
CBS-2231 Brewer	27 3/4 in 700 mm	11 3/4 in 300 mm	20 3/8 in 520 mm	3.3 gallon 12.4 L	29 lbs 13.2 kg	55 lbs 25.0 kg	41 lbs 18.6 kg	30" x 17" x 22" 76.2 x 43.2 x 55.9 cm
CBS-2232 Brewer	27 3/4 in 700 mm	19 ¾ in 500 mm	20 3/8 in 520 mm	6.0 gallon 22.4 L	47 lbs 21.3 kg	92 lbs 41.7 kg	55 lbs 25.0 kg	30" x 23" x 25" 76.2 x 58.4 x 63.5 cm
Calibrated for 3.8 L/1.0 gal brew		Brew Basket 13" X 5"		Coffee Filter 13" X 5 or FETCO# F002"				1" legs standard 2.5" legs optional

Rough-In Drawings

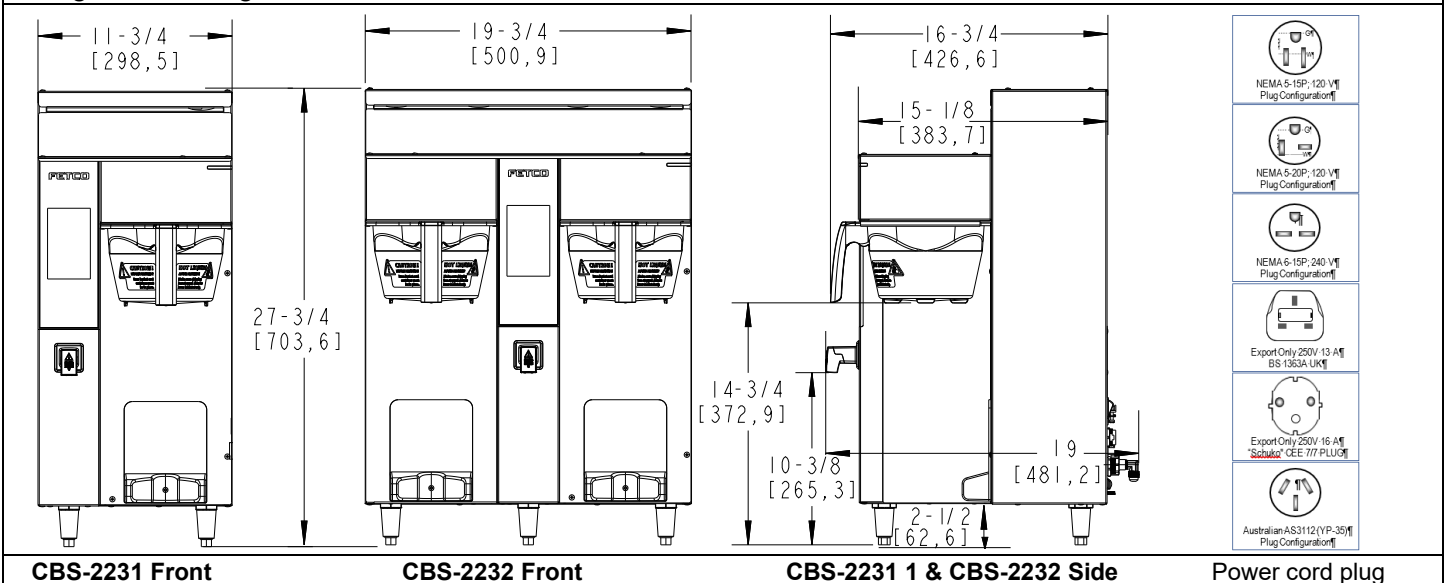

EXAMPLE: SKU E2231US-1X117-PM001													SKU NUMBER IDENTIFICATION KEY			
Product Line	Level	Family	Region ID	Phase	Voltage Range	# Heaters	Individual Heater Wattage	Brew Basket	Hot Water Faucet	Bypass	Brew Basket Locks	Power Cord				
E	2	2	3	1	U S	1	A	1	1	5	P	M	0	0	1	
E=extractor					US =United States	1	A = 100-120	1	1.5	P=plastic	M=manual	1=Yes	1=Yes	0=Terminal Block		
	12=PLUS Series	31= single side			IN = International	2	B = 200-240	2	1.7	M=metal	A=automatic	0=No	0=No	1= NEMA 5-15P		
	22=Next Generation	32= dual side			CE = IEC	3	C = 380-415	3	2.3	C=metal with clips	N=None			2=NEMA 5-20P		
					NM = NOM	U = 1 or 3	D = 440-480	6	3.0					3=NEMA 6-15P		
							X=120 or 240 Dual Voltage		4.0					4=NEMA 6-30P		
									5.0					5=CEE 7/7 Schuko		
														6=UK1-13P		
														7= AUSTRALIAN AS3112 (YP-35)		

Electrical and Output Specifications

CBS-2231 Next Gen Single 3.0-4.0 Liter Coffee Brewers Field configurable Domestic								
Electrical and Output Specifications Brewer has factory installed cord and plug & terminal block 50Hz or 60Hz								
SKU	Voltage	Heater Configuration	Wires	KW	Electrical Connection	Phase	Amp Draw	Brew-Volume per hour
E2231US-1X117-PA011	120	1 X 1.7 kW	2+G	1.7	NEMA 15-5P	1	14.7	3.9 gal/14.8 L
Domestic-Dual Voltage	208-240	2 X 1.7 kW	2+G	2.6-3.4	Terminal Block	1	12.8-14.7	5.8 gal/22 L
Electrical Specifications, Domestic Single brewer-single voltage 120 volt cord and plug single phase 50Hz or 60Hz								

CBS-2231 Next Gen Single 3.0-4.0 Liter Coffee Brewers Domestic models								
Electrical and Output Specifications All brewers have factory installed cord and plug 50Hz or 60Hz								
SKU	Voltage	Heater Configuration	Wires	KW	Electrical Connection	Phase	Amp Draw	Brew-Volume per hour
E2231US-1A115-PA011	120	1 X 1.5 kW	2+G	1.5	NEMA 15-5P	1	13.0	4.0 gal/15.1 L
E2231US-1A123-PA012	120	1 X 2.3 kW	2+G	2.3	NEMA 5-20P	1	19.7	5.8 gal/22 L

CBS-2231 Next Gen Single 3.0-4.0 Liter Coffee Brewers Field configurable NOM (Mexico) In Spanish								
Electrical and Output Specifications Brewer has factory installed cord and plug & terminal block 50Hz or 60Hz								
SKU	Voltage	Heater Configuration	Wires	KW	Electrical Connection	Phase	Amp Draw	Brew-Volume per hour
E2231NM-1X123-PA012	120	1 X 2.3 kW	2+G	2.3	NEMA 5-20P	1	19.7	6.1 gal/23.2 L
Dual Voltage	208-240	2 X 2.3 kW	2+G	4.6	Terminal Block	1	17.1-19.7	7.6 gal/30 L
NM in SKU suffix (above) denotes equipment with NOM certification, Spanish labeling for Mexico and Spanish language user guide								

CBS-2231 Next Gen Single 3.0-4.0 Liter Coffee Brewers International models								
Electrical and Output Specifications All brewers have terminal block electrical utility connection 50Hz or 60Hz								
SKU	Voltage	Heater Configuration	Wires	KW	Electrical Connection	Phase	Amp Draw	Brew-Volume per hour
E2231NM-1A123-PA012	120	1 X 2.3 kW	2+G	2.3	NEMA 5-20P	1	19.7	5.8 gal/22 L
E2231NM-1A123-PA012	208-240	1 X 3.0 kW	2+G	2.3-3.0	NEMA 6-15P	1	11.3-13.0	7.9 gal/30.0 L
NM in SKU suffix (above) denotes equipment with NOM certification, Spanish labeling for Mexico and Spanish language user guide								
E2231IN-1B123-PA010	200-240	1 X 2.3 kW	2+G	1.6-2.3	Terminal Block	1	8.5-10.1	5.8 gal/22 L
E2231IN-1B130-PA010	200-240	1 X 3.0 kW	2+G	2.1-3.0	Terminal Block	1	10.9-13.0	7.7 gal/29.1 L

CBS-2232 Next Gen Dual 3.0-4.0 Liter Coffee Brewers Domestic models								
Electrical and Output Specifications All brewers have terminal block electrical utility connection 50Hz or 60Hz								
SKU	Voltage	Heater Configuration	Wires	KW	Electrical Connection	Phase	Amp Draw	Brew-Volume per hour
E2232US-1B223-PA010	208-240	2 X 2.3 kW	2+G	3.5-4.6	Terminal Block	1	17.1-19.7	11.0 gal/42.0 L
E2232US-1B223-MA110	208-240	2 X 2.3 kW	2+G	3.5-4.6	Terminal Block	1	17.1-19.7	11.0 gal/42.0 L
E2232US-1B230-PA010	208-240	2 X 3.0 kW	2+G	4.5-6.0	Terminal Block	1	22.2-25.5	14.3 gal/54 L
E2232US-1B230-PA110	208-240	2 X 3.0 kW	2+G	4.5-6.0	Terminal Block	1	22.2-25.5	14.3 gal/54 L
E2232US-1B230-MA110	208-240	2 X 3.0 kW	2+G	4.5-6.0	Terminal Block	1	22.2-25.5	14.3 gal/54 L

CBS-2232 Next Gen Dual 3.0-4.0 Liter Coffee Brewers International models								
Electrical and Output Specifications All brewers have terminal block electrical utility connection 50Hz or 60Hz								
SKU	Voltage	Heater Configuration	Wires	KW	Electrical Connection	Phase	Amp Draw	Brew-Volume per hour
E2232IN-1B223-PA010	200-240	2 X 2.3 kW	2+G	3.2-4.6	Terminal Block	1	16.5-19.7	12.2 gal/46.3L
E2232IN-1B230-PA010	200-240	2 X 3.0 kW	2+G	4.2-6.0	Terminal Block	1	21.3-25.5	15.8 gal/60 L
E2232IN-1B230-MA110	200-240	2 X 3.0 kW	2+G	4.2-6.0	Terminal Block	1	21.3-25.5	15.8 gal/60 L
E2232NM-1B230-PA010	208-240	2 X 3.0 kW	2+G	4.5-6.0	Terminal Block	1	22.2-25.5	15.8 gal/60 L
NM in SKU suffix (above) denotes equipment with NOM certification, Spanish labeling for Mexico and Spanish language user guide								

Customer options	BREW BASKET TYPE (P, M)	HOT WATER FAUCET (M, A OR N)	BYPASS (1 OR 0)	Brew Basket Lock (1 OR 0)
* is factory standard feature Add all the following numbers after all SKU numbers	*P=Plastic M=Gourmet Metal	*M=Standard manual A=Automatic electronic N=No hot water faucet	*1=With 0=None	*1=With 0=None

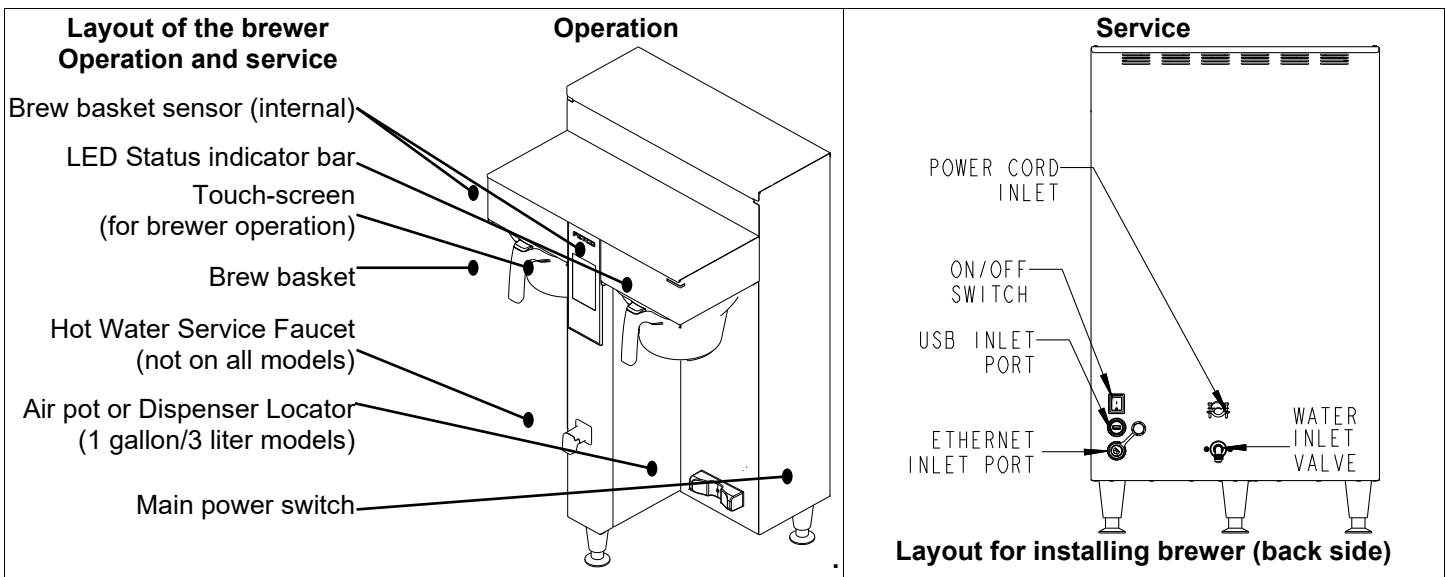

Fast Start brewing

Starting The Brew

- Turn the power switch "ON". (Twin Shown)
- Prepare a brew basket with the correct size filter and appropriate amount of coffee. (4-8 ounces or 113-227 grams for 1 gal/3.8 liters)
- Slide the brew basket completely into the rails.
- Place a clean, empty, preheated dispenser under the brew basket.
- Select a batch & touch the corresponding BREW icon (Batch #1 selected in illustration), then press "START"
- STOP icon will illuminate,
-Countdown time will display, with proportional graphic circle icon
-LED indicator will pulse.
-All other BREW icons for that brew head will be hidden.
....-Opposite side BREW icons on dual brewer remain active
- When the brew cycle is finished,
-Spray icon will extinguish, and the BREW circular icon will remain. This indicates that coffee may still be dripping from the brew basket
For safety- do not remove brew basket until drip-out is complete.

Twin Brewer ready to brew. Brew in process
 Batch one-top left brew position selected Batch one selected

Programming

To enter programming

- Turn the power switch "OFF", then "ON" Bootup will begin.

After 15 second bootup

Tap the FETCO of the screen, shown on right→

Bootup screen

- (Shown right→) Operator password is 1,2,3,4: Note: For general use

Service password is 9,8,7,6 Note: Do not distribute this number

Password screen

- Make changes and adjustments from the Programming Menu screen

(Shown right→)

See progamming menu layout next page

Programming access

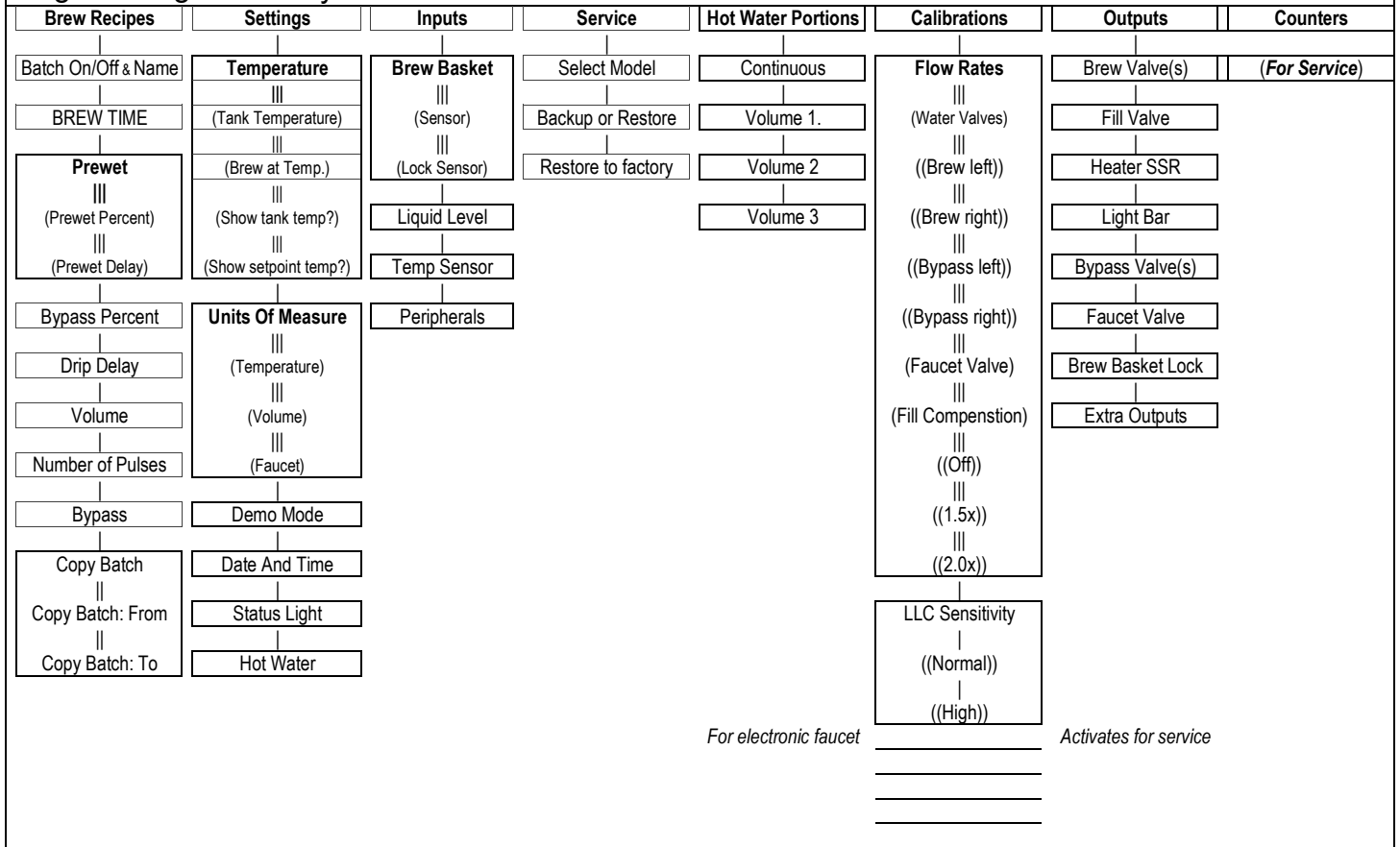

Programming Menu Layout

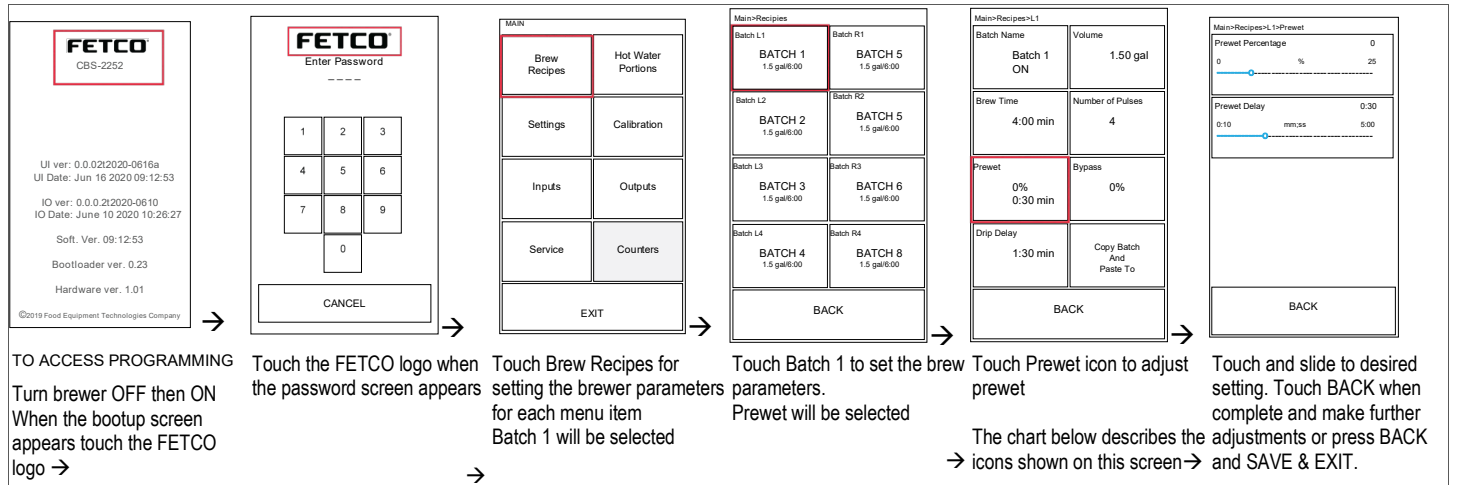

For electronic faucet _____ Activates for service



Brew Recipes	Program Items	Factory set Default	Programming Range	Notes
Batch Name	Batch On/Off	All "ON"	On/Off	Only top batch(s) are always enabled
Batch Name	Customize Name	Batch (1-4 L) (5-8 R)	Complete keypad	Scroll and tap three virtual keypads
Brew Time	Time of brew	4:00 minutes	2:00-12:00 mins/secs	Add to prewetting and drip delay times
Prewet	Prewet percentage	0	0-25% brew volume	Initial wetting to stabilize very fresh coffee
Prewet	Prewet delay time	1:00 sec.	0:10 sec to 5:00 min	Pause after coffee bed is prewitted
Drip Delay	Pause after brew	2:00 min:sec.	00.30 to 6:00	Time that brew basket remains locked during drip-out. This is a safety feature.
Brew Volume	Total volume	1 gallon/3.8 liters	0.5-1.25 gal./0.95-4.75 liters	Factory set for 1 gallon dispenser
Number of Pulses	Start/stop in brew	8	4-20	Algorithm evenly divides brew time cycle
Bypass Percentage	Diverts brew water	0	0-40% of brew volume	Affects flavor, strength and mouth-feel
Copy & Paste Menu	Current recipe		Paste into all other recipes	Will paste selected into the other

Settings	Program Items	Factory set Default	Programming Range	Notes
Temperature	Tank Temperature	200°F/92°C	170-208°F/77-98°C	Hot water tank, brewing water temp.
Temperature	Brew at Temperature*	ON	OFF/ON	See note below
Temperature	Show Tank Temp.	ON	OFF/ON	Shows 1 st at top right screen
Temperature	Show Setpoint Temp.	ON	OFF/ON	Shows 2 nd at top right screen
Units of Measure	Temperature Volume Hot water Faucet	F° - Fahrenheit Gal-Gallons ml - Milliliters	NO or YES	Main>Settings>UNITS Temperature  Volume  Faucet 
ECO Mode	ON/OFF Eco idle time (to start) Eco Tank temperature	OFF (default) (if activated) 1 hour 169°F	Turn on or off 1-6 hours 158°F to 176°F	Screen will display Eco Mode when activated-will take time to reheat to set brew water temperature
Water Filter	Water filter installed Rated filtering volume	NO 2625 gallons	NO or YES 250 gallons to 3950 gallons	
Demo Mode	Brewer ON Disables valves & heaters	OFF	OFF/ON	For training and user familiarization
Hot Water	Digital H. Wtr Faucet	Auto	ON/OFF/Automatic	Automatic activates portion control
Status Light	READY LED color	White	White/Blue/Green	Color when brewer is ready to brew
Screen Saver	Covers recipe screen	OFF	ON/OFF & Timeout setting	"OFF" leaves recipe screen
Date and Time	Set unit date and time	12 hour format	12/24 hour format & date	Store in real time clock

NOTES: Brew at Temperature*

Brew At Temp: "ON"

(Default: factory programmed into brewer)

"BREW START" will not be accessible until tank temperature is at set point.

"BREW START" becomes accessible when hot water tank is at the selected temperature.

Menu screen will be dimmed if tank temperature is low

Brew At Temp: "OFF" USER SELECTABLE (Not recommended)

Allows brewing at any temperature above 170°F/77°C.

May not apply for two sided brewer if one side is in brew cycle

Altitude Correction Chart

Chart to correct for altitude for boiling point in tank water temperature.					
[ft]	[m]	Suggested Setting[°F]	Boiling point[°F]	Suggested Setting[°C]	Boiling point [°C]
0	0	205	212.0	96	100.0
500	152	205	211.0	96	99.5
1000	305	200	210.1	93	98.9
2000	610	200	208.1	93	97.8
2500	762	200	207.2	93	97.3
3000	914	200	206.2	93	96.8
3500	1067	197	205.3	92	96.3
4000	1219	195	204.3	91	95.7
4500	1372	194	203.4	90	95.2
5000	1524	194	202.4	90	94.7
5500	1676	193	201.5	89	94.2
6000	1829	192	200.6	89	93.6
6500	1981	191	199.6	88	93.1
7000	2134	190	198.7	87	92.6
7500	2286	188	197.8	86	92.1
8000	2438	187	196.9	86	91.6
8500	2591	185	196.0	85	91.1

Brew At Temperature

Ideal brew water temperature is 200°F/93°C. After brewing, brewers can take time to recover the hot water tank temperature and signal READY to brew. This is called "recovery time". The lag in recovery time is caused rapid brewing cycles in a rush, low power heating elements, cold water supply temperature even the barometric pressure.

Operators will adjust the "Brew At" temperature to allow the brewing at lower temperatures. This will allow a *slightly* faster recovery time and give a small increase in brew cycles per hour.

Reduced brew temperature will always compromise the quality of the finished brew and lower the temperature of the customers coffee.

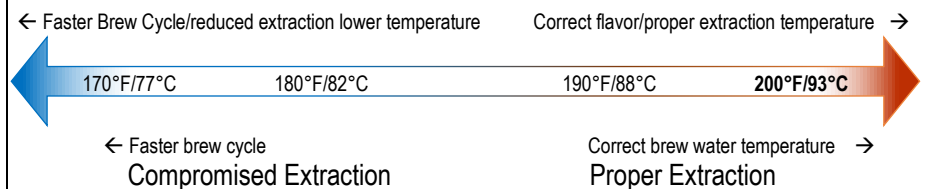

Inputs	Program Items	Factory set Default	Programming Range	Notes
Brew Basket	Sensor	Displays activity	Brew basket in place?	LEFT <input type="radio"/> RIGHT <input type="radio"/> (green=on;red=off)
Brew Basket	Lock Sensor	Displays activity	Brew basket locked?	LEFT <input type="radio"/> RIGHT <input type="radio"/> (green=on;red=off)
Liquid Level	LOW	Not used	Not used	Not used
Liquid Level	HIGH	Hot water tank fill	Filled/Not Filled & signal	Green=Filled/Red=Not Filled
Temp. Sensors	Sensor 1	Hot water tank temp.	Actual temperature & signal	
Temp. Sensors	Sensor 2	Not used	Not used	Not used
Peripherals	USB1	Digital input/output	Displays activity	(green=active;red=off)
Peripherals	USB2	Not used	Not used	Not used
Peripherals	RS-232	Digital input/output	Displays activity	(green=active;red=off)

Service	Program Items	Factory set Default	Programming Range	Notes
Select Model	Set brewer model	CBS-2232	MODEL (single side) 1 (dual side) 2 223x <input type="radio"/> <input type="radio"/> 224x <input type="radio"/> <input type="radio"/> 225x <input type="radio"/> <input checked="" type="radio"/> 226x <input type="radio"/> <input type="radio"/>	To select: touch icon for brewer, touch "BACK" and got to EXIT & SAVE
Enable Options			Options Electric HW faucet <input type="checkbox"/> OFF <input type="checkbox"/> ON Bypass Valve(s) <input type="checkbox"/> OFF <input type="checkbox"/> ON Brew Basket Lock(s) <input type="checkbox"/> OFF <input type="checkbox"/> ON Expansion Board <input type="checkbox"/> OFF <input type="checkbox"/> ON	
Overrides			Override Safety Features Left Right Brew Basket Sensor <input type="checkbox"/> OFF <input type="checkbox"/> ON <input type="checkbox"/> OFF <input type="checkbox"/> ON Brew Basket Lock <input type="checkbox"/> OFF <input type="checkbox"/> ON <input type="checkbox"/> OFF <input type="checkbox"/> ON Br. Basket Lock Sensor <input type="checkbox"/> OFF <input type="checkbox"/> ON <input type="checkbox"/> OFF <input type="checkbox"/> ON HW Press and hold <input type="checkbox"/> OFF <input type="checkbox"/> ON <input type="checkbox"/> OFF <input type="checkbox"/> ON	
Backup or Restore	Backup current configuration	Will save all programmed settings	Requires USB thumb drive	Insert USB thumb drive and touch "BACKUP" & follow instructions
Backup or Restore	Installs saved settings	USB thumb drive with one file-	One file, must be titled: backup.txt	Insert USB thumb drive and touch "RESTORE" & follow instructions
HW/SW/BL Version			Software UI 0.2.221011a IO 0.3.20221119a Bootloader UI Bootloader IO Compilation Time UI Oct 11 2022 13:28:09 IO Nov 29 2022 15:12: 20 Hardware Main Board rev IO Board rev	
Restore Defaults	Return factory sets		Will overwrite all settings	Touch and hold icon 5 seconds
Error Codes			Error Log Error Code→ Code & definition Date/time stamp Export Log To USB Follow prompts to export Error Statistics Error code frequency Error Statistics Follow prompts to delete	
Reset Passcodes	Overrides default		Operator Code Follow prompts to change Service Code Follow prompts to change	
Languages	Reserved for future use			

Error Codes (From SERVICE – Page7)			
DO NOT CLEAR ERROR CODES UNTIL ERROR IS IDENTIFIED AND CORRECTED →Contact factory or specialized personnel for error codes			
Code	Description	Possible Cause	Corrective Action
001	Software error-error on start up or corrupted software	Improper start-up or shutdown	Restart, if still fault: reload software
002	Internal flash corrupted internal data memory malfunction	Error found in cyclic redundancy check CRC	Restart, if still fault: reload software If not corrected: replace board
010	Front U/I board loses communication with the interior O/I board	No communication between front panel	Cycle brewer Off then On. Check cable connections
011	Front U/I board bad communication with the interior O/I board	Disrupted communication Cable connections loose	Cycle brewer Off then On. Check cable connections
Error codes 10 and 11 may be generated by loose connections, electronic interference, or a software/bootloader issue. For assistance by email: open the SERVICE menu and go to the <u>HW/SW/BL Version</u> . Send a cellphone picture of this screen to techsupport@fetco.com with the serial number of the equipment and your return phone number. For live service, write down the screen information or have the HW/SW/BL Version available and contact FETCO by phone at (800) 338-2699 option 2) to discuss with Technical Service. (Email support is usually faster) The correction for ERROR 10 or 11 may require a simple Off/On power cycle or a bootloader/firmware update that can be sent by email. Contact FETCO as above if cycling power or connections do not correct the fault.			
050	Short-circuit in temperature probe	Probe failure.	Replace probe.
051	Open temperature probe.	Bad probe connection, or probe failure.	Check all connections. Replace probe if necessary.
100	Initial Fill Error. Initial fill time took longer than expected after powering up.	Water supply flow rate is too low, fill valve is stuck, water line kinked or closed.	Reboot machine. If persists-investigate cause of low flow rate. (Clogged water filter, kinked line, stuck fill valve)
101	Error on refill- Tank did not refill within expected time.	Water supply flow rate to hot water tank is too low, or fill valve stuck or damaged (SEE PAGE 13)	Check water supply line. Flow should be 20-75 psig, (138-517kPa) >1gal/3.8L/min Investigate cause of low flow rate. If the flow rate is in range-replace fill valve
200	Heating flatline-Tank is boiling	Heater is on, temperature is not rising/dropping	High elevation correction. Bad heaters or temperature probe or position
201	If the hot water tank heaters are turned on during a heating cycle and tank temperature is not increasing according to software logic and the tank temperature is below setpoint	1) Failure of SSR, high limit, temperature probe, or heating element. 2) Water being removed by hot water faucet during heating (control displays "heating")	1)Test and check SSRs, high limit devices temperature probe. Check heating elements with current clamp, replace if necessary. 2)Advise staff to refrain from taking large amounts of water from hot water tank, especially during "heating".
202	Heater Shorted or Stuck SSR	Heater is off and heating SSR is stuck "ON"	Check ohms on heater (15-60Ω). SSR may be stuck in ON mode-replace SSR.
255	Keyboard [HID] error (<u>H</u> uman <u>I</u> nterface <u>D</u> evice)	Usually from longer than 10 seconds' contact. Or faulty reassembly after service	Restart, if still fault: reload software. If mechanical: replace module
NO BSKT <u>Insert Brew Basket</u>		Brew basket must be in place This is a SAFETY FEATURE	Insert brew basket into brewer rails to enable brewer

Hot Water Portions	Program Items	Factory set Default	Programming Range	Notes
This setting is only for brewers with an electronic hot water faucet. In the <u>SETTINGS</u> menu, the "Automatic" feature must be enabled				
Hot Water Portions	Enabled	"ON"		OFF/ON
Hot Water Portions	Name	Continuous	Rename on keypad	Scroll and tap three virtual keypads
	Safety Timeout	0:25	0:10 min 0:60 -----○----- Scroll and go to EXIT&SAVE	Sets limit for touch and dispense
Hot Water Portions	Volume 1	6 oz.		
	Enabled	ON	Turns "ON" or "OFF"	OFF/ON
	Name	Volume 1	Rename on keypad	Scroll and tap three virtual keypads
	Volume dispensed	6 oz	Volume 6 2 oz 30 -----○----- Scroll and go to EXIT&SAVE	Sets limit for #1 touch and dispense
Hot Water Portions	Volume 2	8 oz		
	Enabled	ON	Turns "ON" or "OFF"	OFF/ON
	Name	Volume 2	Rename on keypad	Scroll and tap three virtual keypads
	Volume dispensed	8 oz	Volume 8 2 oz 30 -----○----- Scroll and go to EXIT&SAVE	Sets limit for #2 touch and dispense
Hot Water Portions	Volume 3	8 oz		
	Enabled	ON	Turns "ON" or "OFF"	OFF/ON
	Name	Volume 3	Rename on keypad	Scroll and tap three virtual keypads
	Volume dispensed	12 oz	Volume 12 2 oz 30 -----○----- Scroll and go to EXIT&SAVE	Sets limit for #3 touch and dispense

Calibration	Program Items	Factory set Default	Programming Range	Notes
Flow Rates Water Valves	Brew left	1800 ml/min	Brew Left 1800 (ml) 1450 ml/min 2100 -----○----- Scroll and go to EXIT&SAVE	Use to attenuate and compensate for variations in brew valve output
Flow Rates Water Valves	Brew right	1800 ml/min	Brew Right 1800 (ml) 1450 ml/min 2100 -----○----- Scroll and go to EXIT&SAVE	Use to attenuate and compensate for variations in brew valve output
Flow Rates Water Valves	Bypass left	1350 ml/min	Bypass left 1350 (ml) 1050 ml/min 1600 -----○----- Scroll and go to EXIT&SAVE	Use to attenuate and compensate for variations in bypass valve output
Flow Rates Water Valves	Bypass right	1350 ml/min	Bypass right 1350 (ml) 1050 ml/min 1600 -----○----- Scroll and go to EXIT&SAVE	Use to attenuate and compensate for variations in bypass valve output
Flow Rates Faucet Valve	For automatic hot water faucet	1500 ml/min	Faucet 1500 500 ml/min 5000 -----○----- Scroll and go to EXIT&SAVE	To compensate variations in timed dispense from automatic hot water faucet
Fill Compensation	Slow Flow Compensation	OFF	○ Off ○ .. 1.5x ○ 2.5x Scroll and go to EXIT&SAVE	Use for FloJet bottled water supply or for reduced water supply from mains.
Display			Display % Contrast 10 -----○----- 70 100 Brightness % 20 -----○----- 70 100	
LLC		NORMAL	○ Normal ○ .. High Scroll and go to EXIT&SAVE	Liquid level control sensitivity. Normal for most water. High is for reverse osmosis water or very pure water.

How to calibrate the flow rate

Set the flow rates of the brewer valves to adjust for over or under potting.

Built-in algorithms in brewer controller software corrects brew parameter to customer preferences or to trim variations in flow control components. The control software uses the new flow rate entered in the CALIBRATION screen to adjust and correct the amount of water delivered by the valve.

Increasing the flow rate value DECREASES the volume of brew water dispensed

Decreasing the flow rate value INCREASES the volume of brew water dispensed

Flow rate adjustment will control all batches made by the valve. All batches on the side of the valve will be adjusted, (left or right)

- Obtain the VOLUME DISPENSED of water only, by brewing a batch without coffee or filter paper.
- Obtain the PROGRAMMED VALUE of the same brew. This is displayed on the home screen in the batch box
- Obtain the CURRENT SETTING for the flow rate from the brewer. Do this by entering PROGRAMMING and Tap to "CALIBRATION" then, tap "Flow Rates" and then "Water Valves". The valves flow rate is in the top right corner.

Using the values obtained above to obtain the new flow rate setting to correct the volume dispensed:

Divide the volume dispensed by the programmed volume and then multiply by the current setting

$$\frac{\text{VOLUME DISPENSED}}{\text{PROGRAMMED VALUE}} \times \text{CURRENT SETTING} = \text{NEW FLOW RATE SETTING}$$

- Enter programming mode, tap to "CALIBRATION"
- Tap back to "Flow Rates" and then to "Water Valves"
- Enter the new flow rate into the calibration slider for the valve tested

Note: values for brewers set in gallons are in decimal format. Place all quantities in ounces and divide by 128 (One gallon =128 ounces) to obtain decimal format → 3 quarts delivered=96oz, 96oz÷128=0.75 gal.

Example below shows shortpotting of 16oz over 0.08 gal. batch corrected by recalibration using the formula above

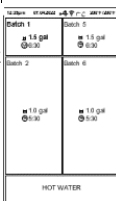
Obtain Volume Dispensed	Obtain Programmed Value	Obtain Current Setting	Use the formula above	Enter the New Flow Rate
Example: A CBS-2232 delivered 3qts or 6oz over the 0.8 gallon (102oz) setting for Batch 2-Left Side (96oz÷128=0.75) The value is 0.75	 The Programmed value for batch 2 -left side of the CBS-2232 is on the home screen in the batch box. The value is 0.8 gallon	The valves flow rate is in the top right corner Brew Left 0.50 (gal) 0.40 gal/min 0.58 -----○----- The value is 0.50	$\frac{0.75}{0.8} \times 0.50 = 0.47$ The new flow rate is 0.47	Brew Left 0.47 (gal) 0.40 gal/min 0.58 -----○----- Enter new setting on the slider as shown and EXIT to save. Retesting recommended

By entering the new flow rate number into the brewer, the software automatically corrects the volume discrepancy

Outputs	Program Items	Factory set Default	Programming Range	Notes
These settings are used to activate individual controls for testing verifications and servicing operations				
Brew Valve(s)	Momentarily operate Left or Right Brew valves		Brew Left Right ↓ ↓	Have dispenser under spray head! Touch to activate flow
Fill Valve	Momentarily operate fill valve		Fill ↓	Have dispenser under spray heads! Touch to activate flow
Heater SSR	Turns on all heaters		Heater ↓ 3 sec max	Activates SSRs to turn on heaters
Light Bar	Momentarily operate light bar(s)		Status Light ↓	
Bypass Valve(s)	Momentarily operates Left or Right Bypass valves		Bypass Left Right ↓ ↓	Have dispenser under bypass port! Touch to activate flow
Faucet Valve	Momentarily operate faucet valve	For brewers with automatic hot water faucet	Faucet ↓	Have dispenser under faucet! Touch to activate flow
Brew Basket Lock	Operates brew basket locks, toggling them on and off		BBL lock Left Right ↓ ↓ BBL Unlock Left Right ↓ ↓ BBL Sensor Left Right ● ●	Will toggle brew basket locks to be engaged then OFF.
Extra Outputs	For future use	Not used	Not used	Not used

Counters	Program Items	Factory set Default	Programming Range	Notes
This setting shows usage of the brewers functions				
Lifetime Counters				
	Service Counters		Main>Counters>Lifetime>Service Lifetime Counters (units in hours and liters) Unit Uptime 0 Fill Valve Volume 0 Activation 0 Heater Time On 0 Activation 0 Hot Water Dispense Count 0 Hot Water Valve Volume 0 Activation 0 Brewer Volume 0 Left Right Brew Count 0 0 Brew Valve Volume 0 0 Activation 0 0 Bypass Valve Volume 0 0 Activation 0 0 Locks Activation 0 0	
	Hot Water Counters		Main>Counters>Lifetime>Faucet Lifetime Counters (units in liters) Volume Activation Continues 0 0 1 0 0 2 0 0 3 0 0	
	Brew Counters		Main>Counters>Lifetime>Brew Lifetime Counters (units in liters) Recipe Number Volume Activation 1 0 0 2 0 0 3 0 0 4 0 0 5 0 0 6 0 0 7 0 0 8 0 0	
	Data Counters	Reserved for future		
Water Filter	Water Filer Life Time			

Brewer Setup

NOTE-Assemble legs after unpacking the brewer and before connection to utilities

1) attach legs for 3 Liter/ 1 Gallon dispensing



1" legs -
Attach this length for
3 Liter air pot configuration
3 required for CBS-2232
4 required for CBS-2231



2-1/2" legs -
Attach this length for
1 Gallon dispenser or 3 liter air pot.
Part number 1073.00016.00
3 required for CBS-2232
4 required for CBS-2231

Legs are sent from factory inside brew basket. Attach legs before installing

2) Adjust dispenser locator for either 3 Liter / 1 Gallon dispensing

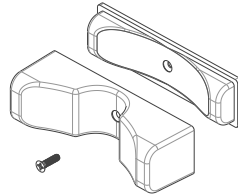
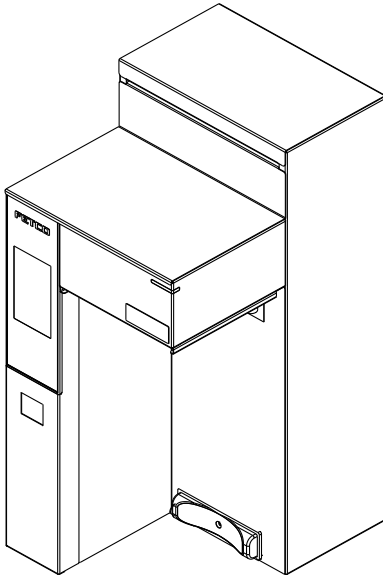

Set Dispenser Locator

← Shown with 1 gallon dispenser
locator
-(User option)

Shown with 3 liter air pot Locator →
-(Factory installed)

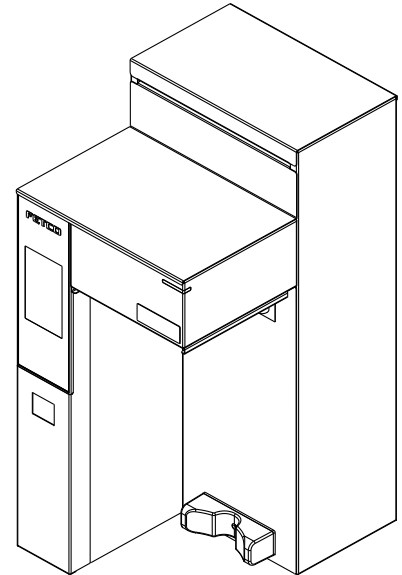

Layout of the brewer

Operation and service

Brew basket
Keypad for brewer operation
Hot Water Faucet

ON/OFF Switch
Air pot or Dispenser Locator
(Two for twin side)

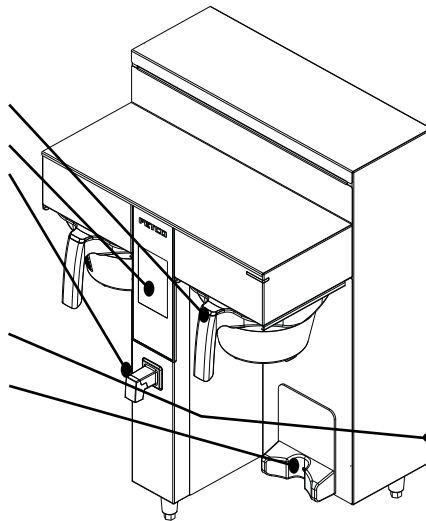

For installing brewer

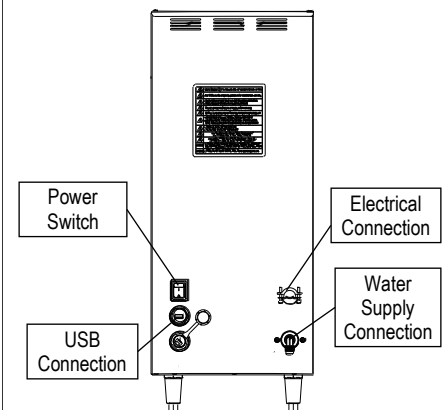

Brewer Setup

Attach water inlet adapter

Place rubber washer with screen in adapter. Hand tighten only-and 1/4 turn with wrench

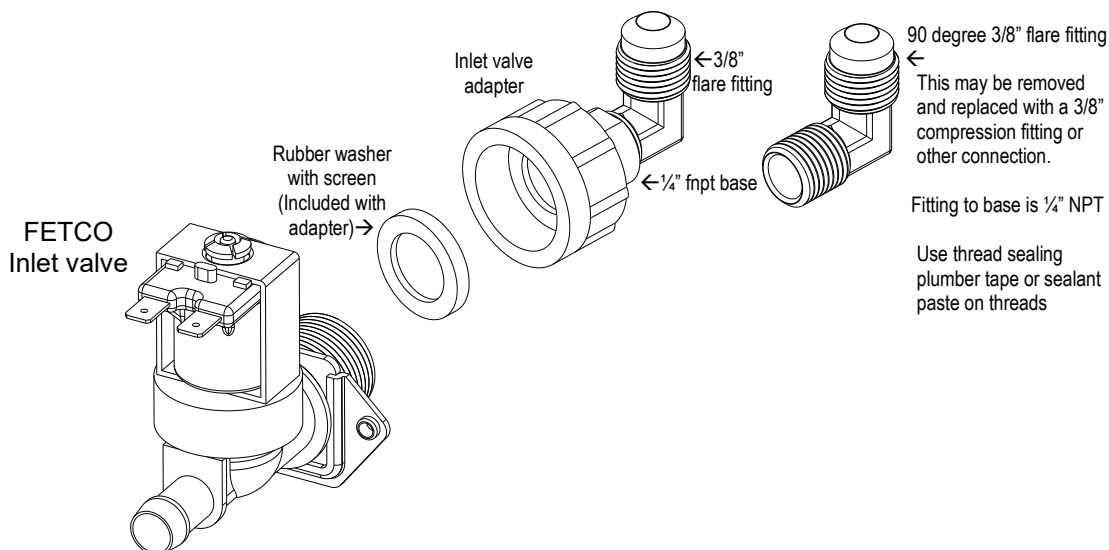

Install the adapter on inlet valve first before attaching water line. Adapter is shipped in the brew basket

The valve threads are 3/4" BSP MALE THREAD and are not 3/4 garden hose fittings.

Use of any other connector to valve will damage the valve

DO NOT use USA dishwasher water adapter or USA washing machine adapter for this connection.

The threads on these USA adapters are unusable for the valve

TO PREVENT DAMAGE AND INSURE PROPER EQUIPMENT OPERATION

The inlet valve thread is 3/4 INCH BSP (British Standard Pipe).

This valve is not a standard USA washing machine or dishwasher thread (3/4" GHT)

-Use only the plumbing adaptor kit included with this equipment. Use the gasket included in adaptor kit

-Plumber's tape is not recommended for the adapter to valve connection

-Hand tighten adapter on valve with gasket, then very lightly wrench 1/4 turn to set

-DO NOT SUBSTITUTE FITTINGS FOR CONNECTING TO WATER SUPPLY

Damage to inlet valve from improper installation will void the warranty

NOTE: DO NOT TANK PLUMB DRAIN. DRAIN IS FOR SERVICE AND MAINTENANCE.

Installation Guide

(For Qualified Service Technicians Only)

General:

If not installed correctly by qualified personnel, the brewer will not operate properly and damage may result. Utilize only qualified beverage equipment service technicians for service and installation. Always have an empty dispenser under spray head of all coffee brewing equipment-including when at idle. Damages resulting from improper installation are not covered by the warranty, and will void the warranty.

Electrical:

All FETCO brewers require **an electrical ground wire**. Installation without grounding is dangerous. Note Equipotentiality Terminal, if present, (To identify the terminals which, when connected together, bring the various parts of equipment or of a system to the same potential, not necessarily being the earth (ground) potential, e.g. for local bonding.) Verify voltages, polarity, circuits, and circuit breaker access before attaching equipment. Brewers in this series wire differently in regards to a neutral wire. Review the wire diagrams. The electrical diagram is located in the User's Guide and online at www.fetco.com. Make sure of the tight grounding of the equipment and use the external ground bolt. The installation must comply with applicable federal, state, and local codes having jurisdiction at your location. Check with your local inspectors to determine what codes will apply.



→See wiring diagrams for connections

Plumbing:

North America: All installations must comply with applicable federal, state, or local plumbing codes.
All Others: The water and waste piping and connections shall comply with the International Plumbing Code 2003, International Code Council (ICC), or to the Uniform Plumbing Code 2003 (IAPMO).
Use an inline water filter for all beverage equipment.
Install the filter unit after a water shutoff valve and in a position to facilitate filter replacement.
The water line and newly installed filter cartage must be flushed thoroughly prior to connecting it to the brewer to prevent debris from contaminating the machine.
Verify that the water line will provide a flow rate of at least 1½gpm/(5.7lpm) per minute and the water pressure is between 20-75 psig (138-517kPa) before making any connections.
Use a wrench on the factory fitting when connecting the incoming water line. This will reduce stress on the internal connections and reduce the possibility of leaks developing after the install has been completed.
Install a backflow prevention device. Most municipalities require a recognized backflow preventer.
Usable on all hot beverage and cold beverage equipment is a WATTS® SD-2 or SD-3.
WATTS spring loaded double check valve models are accepted by most zoning authorities.
→The check valve should be as close to the water supply inlet of the beverage equipment as possible.

Tank Drain

The water tank must be drained before maintenance procedures, and when the unit is to be relocated or shipped.
Disconnect power and water to unit. DANGER: Insure that all utility connections to the brewer are broken.
Move the unit near a sink or obtain a container large enough to hold four gallons of water.
→Note: the hot water tank may hold more than four gallons.
Remove the front panel and tank cover and allow the tank to cool to a safe temperature.
The tank drain line and clamp are located inside-under the hot water tank. Pinch the drain line clamp to close.
Locate the fill valve against the back wall, using pliers, loosen the hose clamp and move it back over the tube.
→Note Do not loosen the hose clamp to the bottom of the hot water tank.
Crimp the tube an inch or two away from the drain plug to prevent water from flowing and pull it off the valve.
Pull the tube end out of the brewer and position over sink or bucket.
Release the crimped tube and hose clamp and allow the water to flow into the sink or container.
Multiple buckets may be needed during the draining, see tank volumes below.

Brewer	Hot Water Tank Capacity	OPEN Leave open for use	
CBS-1231 Single	3.3 gal 12.3 liter	PINCH SHUT To drain tank & service brewer	
CBS-1232 Twin	6.0 gal 22.4 liter		

Operator Training

Review the operating procedures with whoever will be using the brewer.

Pay particular attention to the following areas:

Always pre-heat the dispensers before the first use of each day by filling them halfway with hot water and letting them stand for at least 5 minutes.

Do not remove the brew basket from a coffee brewer until it has stopped dripping.

Make sure the dispenser is empty before brewing into it.

Show how to attach covers, close, and or secure the dispensers for transporting.

Show the location and operation of the water shut off valve as well as the circuit breaker for the brewer.

Steam from the tank will form condensation in the vent tubes. This condensation will drip into and then out of the brew baskets. Up to 1/4 cup/118cc discharging overnight is possible. Place an appropriate container under each brew basket when not in use.

We recommend leaving the power to the brewer on overnight. The water tank is well insulated and very little electricity is used to keep the tank hot. Leaving the brewer in the "ON" position will also avoid delays at the beginning of shifts for the brewer to reach operating temperature.

Cleaning & Maintenance

After Each Brew:

Dispose of grounds and rinse brew basket.

Never strike a brew basket or hit it against a hard surface.

This will damage the brew cone, and may damage the brew basket support rails

Rinse dispensers before reuse.

Every Day:

Wash brew basket with hot sudsy water.

Pull CSD from the spray head, it is magnetically attached. Use gloves or a heavy towel. →

Wash off any film and reattach. Use vinegar if limescale filming is present.

Clean dispensers with hot suds water and a brush, rinse and air dry.

Use only a soft cloth and hot suds on the outside to avoid scratches. Never use abrasives that will scratch surface.

Weekly

Use a commercial coffee dispenser cleaner such as URNEX™, TABZ™, DIP-IT™ or Squeak 'n Clean™.

Carefully Follow the instructions supplied with the cleaning product

Never use spray cleaners, solvent, solvent based cleaner or petroleum based polish anywhere on dispensers

Warning

Turn off power before any cleaning procedure, including wiping the exterior for appearance reasons.

Dry the exterior, especially the face panel, before turning on power.

Do not apply any type of spray cleaner on the face panel of this equipment.

Never use solvent or solvent-based cleaner or petroleum based polish anywhere on this equipment.

Dry the face of the touch pad before turning on power

Do not electrically energize this equipment or attempt operation without all covers in place and all screws fastened.

Unplug machine before disassembly or servicing.

Safety Notes

Professional installation is required. This appliance is manufactured only for commercial use

Operational requirements and maintenance for commercial cooking appliances differ from household appliances.

Operators must be trained for this equipment and must understand the use, maintenance and hazards.

Access to the service area is restricted to persons having safety/hygiene knowledge and practical experience of the coffee brewer. This appliance must be installed in locations where it can be overseen by adult trained personnel.

Do not attempt to move hot beverage equipment once it is filled. Drain equipment before moving.

FETCO commercial coffee brewers prepare large amounts of coffee or tea in a single batch using very hot water

Commercial coffee brewers provide very hot water from the spray head, brew basket and faucet when it is pulled.

Coffee brewers may continue to dispense very hot water from the mechanically operated faucet after the electronic touchpad is completely disabled by turning off the power switch on the lower back of the unit or unplugging the unit.

For safety, the brewer control locks the brew basket for 6.0 minutes after starting the brew.

Never attempt to defeat the factory set (default) time that the brew basket is locked for safety from start of brew.

Keep these instructions for training and future reference.

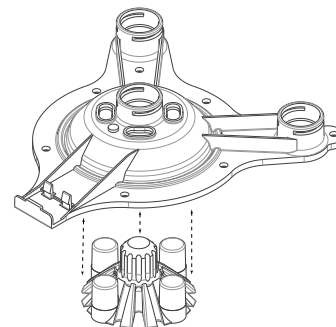

Warning

- Turn off power before any cleaning procedure, including wiping the exterior for appearance reasons.
- Dry the exterior, especially the face panel, before turning on power.
- Do not apply any type of spray cleaner on the face panel of this equipment.
- Never use solvent or solvent-based cleaner or petroleum based polish anywhere on this equipment.
- Dry the face of the touch pad before turning on power
- Do not electrically energize this equipment or attempt operation without all covers in place and all screws fastened.
- Unplug machine before disassembly or servicing.

Installation safety and hygiene directions-For International and CE equipment

- Access to the service area is restricted to persons having safety/hygiene knowledge and practical experience of the coffee brewer. This appliance must be installed in locations where it can be overseen by trained personnel.
- For proper operation, this appliance must be installed indoors where the temperature is between 10°C/50°F to 35°C/95°F. Drain and remove all liquid from equipment and lines if exposed to freezing temperatures.
- All commercial cooking equipment, including this unit, is not intended for use by children or persons with reduced physical, sensory, or mental capabilities. Ensure proper supervision of children and keep them away from the unit.
- Children should be supervised to ensure that they do not play hot beverage equipment.
- This unit must be installed and serviced by qualified personnel only.
- Installation must conform to all local electrical and plumbing codes. Installation by unqualified personnel will void the unit warranty and may lead to electric shock or burn, as well as damage to unit and/or its surroundings.
- If the power cord requires repair or replacement-it must be performed by the manufacturer or authorized service personnel with the specified cord only from the manufacturer in order to avoid a hazard.
- Review the dimensions for the unit and verify that it will fit properly in the space intended for it. Verify that the counter or table will support the total weight of the brewer and dispensers when filled (See: Technical Data).
- Place the brewer on the counter or stand. When the brewer is in position, level it front to back as well as side-to-side by adjusting the legs.
- Brewers will need a sturdy supported surface for operation. Do not move brewers when filled.
- Do not tilt appliance more than 10° to insure safe operation.
- Unit is for protected indoor use only. Do not steam clean or use excessive water on unit.
- This unit is not "jet-proof" construction. Do not pressure wash or use jet spray to clean this unit.
- The unit is not waterproof-do not submerge or saturate with water.

**Equipment exposed to flood and contaminated must not be used due to electrical and food safety.
Do not operate if unit has been submerged or saturated with water.**













WARNING

All electrical connections must be in accordance with local electrical codes and any other applicable codes. If the supply cord is damaged, it must be replaced by the manufacturer, its service agent, or similarly qualified persons in order to avoid a hazard.

To prevent an electric shock hazard this device must be bonded to equipment in close proximity with an equipotential bonding conductor. This device is equipped with a bonding lug for this purpose and is marked with the following symbol



	WARNING To reduce risk of electric shock or fire.
	FETCO® Hot Beverage Equipment is for commercial use only.
	Do not remove or open cover. No user serviceable parts inside. Refer installation and service to qualified personnel.
	Caution, disconnect from power supply before servicing.
	GROUND: National Electrical Code requires separate grounding wire.
	Use dedicated circuit with capacity rated by local code or National Electrical Code for the current draw of this equipment. Check serial number plate on right side for power requirements.
	Locate unit away from source of heat. Do not install or use near combustibles.
	THIS APPLIANCE IS ENERGIZED WHENEVER IT IS CONNECTED TO A POWER SOURCE
	FAILURE TO COMPLY RISKS EQUIPMENT DAMAGE, PROPERTY DAMAGE, FIRE, OR SHOCK HAZARD
	This equipment must be installed with a backflow protection device to comply with federal, state or local municipality codes.
	Read the user guide before installing and operating this unit.

Labels and warnings for hot beverage equipment
Label for BACK PANEL of equipment

(1046.00035.00)

Parts diagrams

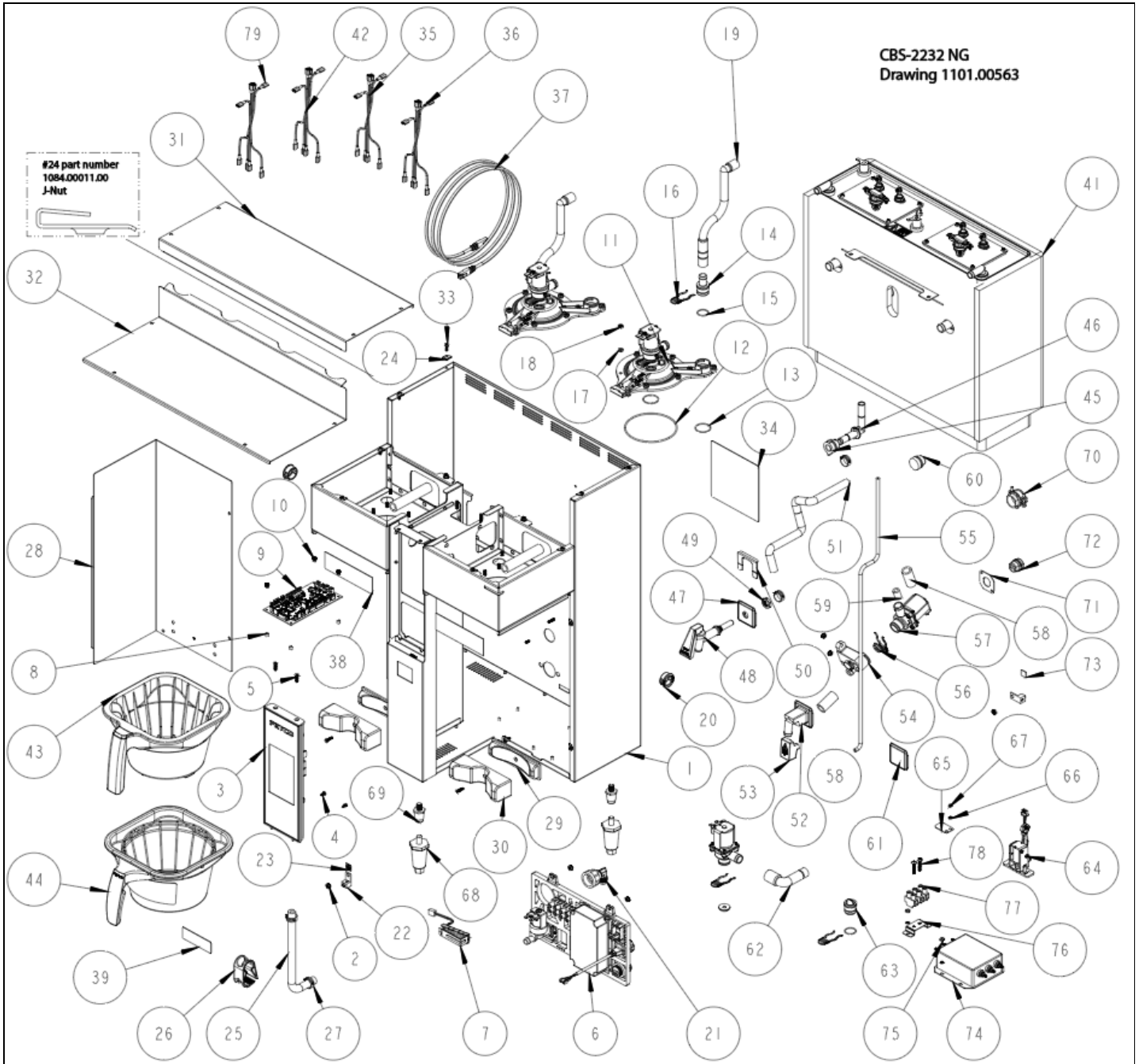

Ref	Qty	PartNumber	Description	Drawing 1101.00563.00 CBS-2232
1	1	1111.00101.00	WELDMENT BODY, CBS-2232	
2	8	1084.00051.00.	NUT, HEX LOCKWASHER, #8-32, 18-8 ST. STL	
3	1	1102.00448.00	FRONT PANEL ASSEMBLY, CBS-2200 SERIES	
4	2	1082.00029.00	SCREW, #6 X 3/8 LG, TRUSS HD PHIL, SHEET MTL	
5	4	1082.00058.00	SCREW, # 8-32 X 5/8, FLAT HD, PH, 18-8 SS	
6	1	See Drawing	ELECTRICAL COMPONENT LATTICE, CBS-2200	
7	1	1102.00444.00	VISUAL COMMUNICATION RGB LED BAR, ASSY	
8	4	1081.00006.00	SPACER, 6MM OD x 3.2MM ID x 5MM LG, Z/P	
9	1	1051.00046.00	CBS-2200 SERIES, I/O BOARD, 24V	
10	4	1029.00006.00	NUT, FINGER KNURLED, #4-40	
11	2	See Drawing	SPRAYHEAD ASSY,CBS-30/40'S, QUICK CONNECT	
12	2	1024.00063.00	O-RING, 3 15/16" x 3/32" CS, DASH # 154, BUNA-N, DURO-A50	
13	4	1024.00107.00	O-RING, 1 3/16" OD X 1 1/16" ID X 1/16" TH, BYPASS SEAL	
14	2	1023.00343.00	VENT INSERT, QUICK CONNECT	
15	3	1024.00106.00	O-RING, 13/16"OD X 11/16"ID X 1/16" TH, FOR QUICK CONNECT	
16	5	1023.00342.00	QUICK CONNECT CLIP	
17	18	1083.00010.00	WASHER, #12 SCREW W/NEOPRENE-BONDED SEAL	

Parts list continues next page

Ref	Qty	PartNumber	Description	Drawing 1101.00563.00 CBS-2232NG	...Continued from page 16
18	18	1084.00006.00	NUT, 8-32 18-8 HEX MACHINE SCREW		
19	2	1024.00098.00	VENT TUBE, CBS- EXTRACTOR SERIES		
20	2	1086.00004.00	BUSHING, SNAP, 1" MOUNTING HOLE		
21	1	1102.00243.00	ADAPTER ASSY, 3/4" BSP x 1/4" NPT x 3/8" TUBE		
22	2	1065.00009.00	GROUND LUG CONNECTOR, 14-2 AWG, ALUMINUM		
23	1	1044.00012.00	LABEL GROUND, CE		
24	11	1084.00011.00	NUT, CLIP ON (J-NUT), #6-32, 22-20 GA., BLK-PH FINISH		
25	1	1025.00058.00	TUBE, 9/16"OD X 5/16"ID X 25.00"LG		
26	1	1086.00009.00	CLAMP, 3/4" MAX TUBE OD FLOW CONTROL		
27	5	1086.00003.00	UNICLAMP, 15.9 HOSE OD CLAMP		
28	1	1112.00530.00	WELDMENT, RIGHT COVER, CBS-2230		
29	2	1023.00354.00	LOCATOR, DISPENSER, CBS-2230		
30	2	1023.00355.00	LOCATOR, AIRPOT ADAPTER, CBS-2230		
31	1	1001.00408.00	COVER TOP, CBS-2232/42		
32	1	1001.00409.00	COVER, UPPER BASE, CBS-2232/42		
33	11	1082.00017.00	SCREW, TRUSS HD. PHIL. MACHINE, # 6-32 X 1/2 LG.		
34	1	1046.00035.00	LABEL, WARNING "TO REDUCE RISK OF ELECTRIC SHOCK OR FIRE"		
35	1	1402.00106.00	HARNESS, CBS-2240/50-NG, LOW AMP, UNIVERSAL		
36	1	1402.00107.00	HARNESS ADDITION, CBS-2242/52-NG, LOW AMP, UNIVERSAL		
37	1	1063.00042.00	ETHERNET CABLE, CAT-7, 5FT LENGTH		
38	2	1046.00003.00	LABEL, CSD WARNING, 1.5" X 5.0"		
39	1	1041.00032.00	BLACK EXTRACTOR NG LABEL, LASER ENGRAVED		
40	2	1025.00142.00	TUBE, SILICONE, 3/4" OD X 1/2" ID X 3.75" LG, BREW		
41	1	See Drawing	TANK ASSEMBLY, CBS-2231		
42	1	1402.00037.10	HARNESS HIGH AMP, CBS-2232/42/51, UL		
43	1	B014218BN2BK	BREW BASKET ASSY, BLACK, 13" X 5", 0.218" DIA HOLE, BROWN PLUG		
44	1	B003218B1	BREW BASKET ASSY, 13" X 5", .218 DIA HOLE, BLACK		
45	1	1024.00111.00	GROMMET, SILICONE, W/ POSITION TABS		
46	1	1023.00362.00	FITTING VENT, ELBOW, .375" X .375", SELF POSITIONING		
47	1	1023.00348.00	HOT WATER INSERT, MANUAL FAUCET		
48	1	1071.00055.00	FAUCET, HOT WATER, PSC-BR-8, WITH FLAT AND STEM		
49	1	1084.00048.00	JAM NUT, 1/2-20 UNF, NICKEL PLATED BRASS		
50	1	1003.00370.00	HOT WATER INSERT LOCK		
51	1	1025.00120.00	TUBE, 9/16"OD X 5/16"ID X 13.00"LG		
52	1	1023.00346.00	HOT WATER INSERT, AUTO FAUCET		
53	1	1029.00041.00	COVER, AUTO HOT WATER FAUCET, SILICONE		
54	1	1023.00347.00	VALVE MOUNT, HOT WATER DISPENSER		
55	1	1025.00026.00	TUBE, 1/4"OD X 1/8"ID X 30"LG, VENT, HOT WATER VAPOR		
56	2	1023.00369.00	ORIFICE INSERT, QUICK CONNECT, 3/16" HOLE		
57	2	1057.00076.00	VALVE ASSEMBLY, COMPLETE, NG, DELTROL		
58	2	1025.00138.00	TUBE, SILICONE, 3/4" OD X 1/2" ID X 1-1/2" LG, HOT WATER		
59	1	1025.00135.00	TUBE, 1/2"OD X 1/4"ID X .75" LG, RESTRICTOR		
60	1	1024.00051.00	GROMMET, SILICONE, BLANK		
61	1	1023.00349.00	HOT WATER INSERT, NO FAUCET		
62	1	1029.00042.00	BYPASS L-TUBE, SILICONE, 2200 SINGLE SERIES		
63	1	1023.00344.00	PLUG INSERT, QUICK CONNECT		
64	1	1102.00445.00	ASSY, BREW BASKET LOCKER W/FEEDBACK		
65	1	1003.00259.00	BRACKET, BREW BASKET LOCK COVER		
66	3	1083.00009.00	WASHER, #6 SCREW , INTL TOOTH LOCKWASHER		
67	1	1084.00010.00	NUT, HEX, #6-32, UNDERSIZED, ZINC PLATED		
68	3	1073.00016.00	LEG, THERMOPLASTIC, 2.50"(63mm)		
69	3	1073.00019.00	LEG, 3/8-16 THREAD x 1" LG., GRAY		
70	1	1086.00008.00	CONNECTOR, CLAMP, NON-METALLIC CABLE, 3/4"		
71	1	1003.00348.00	ADAPTER PLATE, CBS-1130-XV+, STRAIN RELIEF, CE		
72	1	1086.00029.00	BUSHING, STRAIN RELIEF, .360"-.430" DIA CABLE		
73	1	1044.00013.00	LABEL EQUIPOTENTIALITY, CE		
74	1	1052.00027.00	EMI FILTER, THREE LINE 30A, 250/440VAC		
75	2	1084.00012.00	NUT, HEX, #6-32 MACHINE SCREW		
76	1	1112.00246.00	WELDMENT BRACKET TERMINAL BLOCK, 3 POLE		
77	1	1052.00022.00	EUROSTRIP HE10 TERM. BLOCK, 3 POLE, 50AMP, 18-8 AWG		
78	2	1082.00082.00	SCREW, PHILLIP HD., 8-32 THREAD		
79	1	1402.00121.10	WIRE HARNESS ADDITION, HIGH AMP, EMI FILTER, 2-POLE, CE		

#24 part number
1084.00011.00
J-Nut

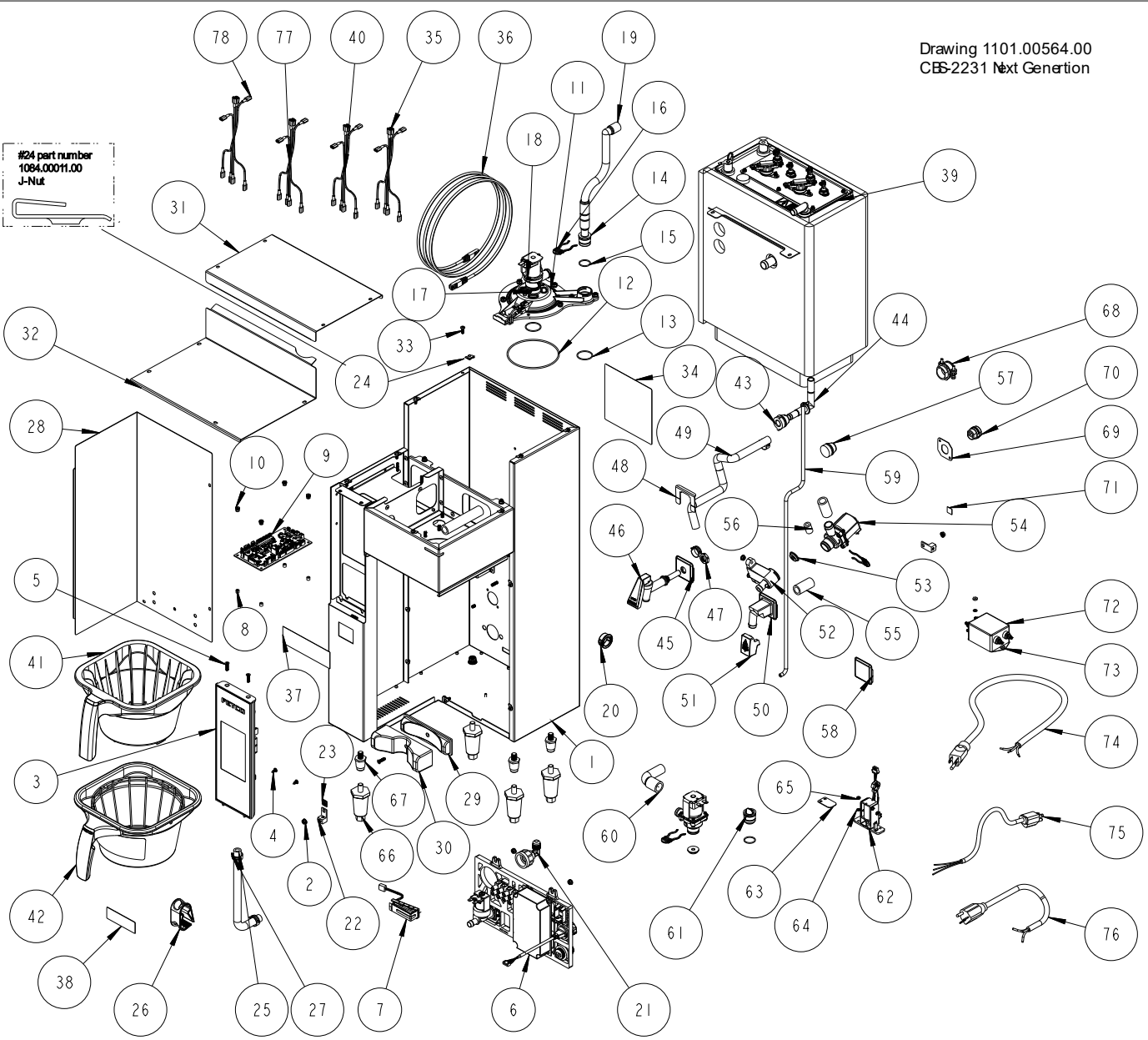

Ref	Qty	Part Number	Description	Drawing 1101.00564.00 CBS-2231NG
1	1	1111.00102.00	WELDMENT BODY, CBS-2231	
2	8	1084.00051.00	NUT, HEX LOCKWASHER, #8-32, 18-8 ST. STL.	
3	1	1102.00448.00	FRONT PANEL ASSEMBLY, CBS-2200 SERIES	
4	2	1082.00029.00	SCREW, #6 X 3/8 LG, TRUSS HD PHIL, SHEET MTL	
5	3	1082.00058.00	SCREW, # 8-32 X 5/8, FLAT HD, PH, 18-8 SS	
6	1	See Drawing	ELECTRICAL COMPONENT LATTICE, CBS-2200	
7	1	1102.00444.00	VISUAL COMMUNICATION RGB LED BAR, ASSY	
8	4	1081.00006.00	SPACER, 6MM OD x 3.2MM ID x 5MM LG, Z/P	
9	1	1051.00046.00	CBS-2200 SERIES, I/O BOARD, 24V	
10	4	1029.00006.00	NUT, FINGER KNURLED, #4-40	
11	1	See Drawing	QUICK CONNECT SRAYHEAD ASSEMBLY,30/40'S, BASIC	
12	1	1024.00063.00	O-RING, 3 15/16" x 3/32" CS, DASH # 154, BUNA-N, DURO-A50	
13	2	1024.00107.00	O-RING, 1 3/16" OD X 1 1/16" ID X 1/16" TH, BYPASS SEAL	
14	1	1023.00343.00	VENT INSERT, QUICK CONNECT	
15	2	1024.00106.00	O-RING, 13/16"OD X 11/16"ID X 1/16" TH, FOR QUICK CONNECT	
16	3	1023.00342.00	QUICK CONNECT CLIP	
17	9	1083.00010.00	WASHER, #12 SCREW W/NEOPRENE-BONDED SEAL	
18	9	1084.00006.00	NUT, 8-32 18-8 HEX MACHINE SCREW	
19	1	1024.00098.00	VENT TUBE, CBS- EXTRACTOR SERIES	

Parts list continues next page

Ref	Qty	PartNumber	Description	Drawing 1101.00564.00 CBS-2231NG	...Continued from page 20
20	1	1086.00004.00	BUSHING, SNAP, 1" MOUNTING HOLE		
21	1	1102.00243.00	ADAPTER ASSY, 3/4" BSP x 1/4" NPT x 3/8" TUBE		
22	2	1065.00009.00	GROUND LUG CONNECTOR, 14-2 AWG, ALUMINUM		
23	1	1044.00012.00	LABEL GROUND, CE		
24	11	1084.00011.00	NUT, CLIP ON (J-NUT), #6-32, 22-20 GA., BLK-PH FINISH		
25	1	1025.00058.00	TUBE, 9/16"OD X 5/16"ID X 25.00"LG		
26	1	1086.00009.00	CLAMP, 3/4" MAX TUBE OD FLOW CONTROL		
27	4	1086.00003.00	UNICLAMP, 15.9 HOSE OD CLAMP		
28	1	1112.00530.00	WELDMENT, RIGHT COVER, CBS-2230		
29	1	1023.00354.00	LOCATOR, DISPENSER, CBS-2230		
30	1	1023.00355.00	LOCATOR, AIRPOT ADAPTER, CBS-2230		
31	1	1001.00413.00	COVER TOP, CBS-2231/41		
32	1	1001.00414.00	COVER, UPPER BASE, CBS-2231/41		
33	11	1082.00017.00	SCREW, TRUSS HD. PHIL. MACHINE, # 6-32 X 1/2 LG.		
34	1	1046.00035.00	LABEL, WARNING "TO REDUCE RISK OF ELECTRIC SHOCK OR FIRE"		
35	1	1402.00106.00	HARNESS, CBS-2240/50-NG, LOW AMP, UNIVERSAL		
36	1	1063.00042.00	ETHERNET CABLE, CAT-7, 5FT LENGTH		
37	1	1046.00003.00	LABEL, CSD WARNING, 1.5" X 5.0"		
38	1	1041.00032.00	BLACK EXTRACTOR NG LABEL, LASER ENGRAVED		
39	1	See Drawing	TANK ASSEMBLY, CBS-2231		
40	1	1402.00039.10	HARNESS HIGH AMP, CBS-2231/41/51, UL		
41	1	B014218BN2BK	BREW BASKET ASSY, BLACK, 13" X 5", 0.218" DIA HOLE, BROWN PLUG		
42	1	B003218B1	BREW BASKET ASSY, 13" X 5", .218 DIA HOLE, BLACK		
43	1	1024.00111.00	GROMMET, SILICONE, W/ POSITION TABS		
44	1	1023.00362.00	FITTING VENT, ELBOW, .375" X .375", SELF POSITIONING		
45	1	1023.00348.00	HOT WATER INSERT, MANUAL FAUCET		
46	1	1071.00055.00	FAUCET, HOT WATER, PSC-BR-8, WITH FLAT AND STEM		
47	1	1084.00048.00	JAM NUT, 1/2-20 UNF, NICKEL PLATED BRASS		
48	1	1003.00370.00	HOT WATER INSERT LOCK		
49	1	1025.00120.00	TUBE, 9/16"OD X 5/16"ID X 13.00"LG		
50	1	1023.00346.00	HOT WATER INSERT, AUTO FAUCET		
51	1	1029.00041.00	COVER, AUTO HOT WATER FAUCET, SILICONE		
52	1	1023.00347.00	VALVE MOUNT, HOT WATER DISPENSER		
53	2	1023.00369.00	ORIFICE INSERT, QUICK CONNECT, 3/16" HOLE		
54	2	1057.00076.00	VALVE ASSEMBLY, COMPLETE, NG, DELTROL		
55	2	1025.00138.00	TUBE, SILICONE, 3/4" OD X 1/2" ID X 1-1/2" LG, HOT WATER		
56	1	1025.00135.00	TUBE, 1/2"OD X 1/4"ID X .75" LG, RESTRICTOR		
57	1	1024.00051.00	GROMMET, SILICONE, BLANK		
58	1	1023.00349.00	HOT WATER INSERT, NO FAUCET		
59	1	1025.00026.00	TUBE, 1/4"OD X 1/8"ID X 30"LG, VENT, HOT WATER VAPOR		
60	1	1029.00042.00	BYPASS L-TUBE, SILICONE, 2200 SINGLE SERIES		
61	1	1023.00344.00	PLUG INSERT, QUICK CONNECT		
62	1	1102.00445.00	ASSY, BREW BASKET LOCKER W/FEEDBACK		
63	1	1003.00259.00	BRACKET, BREW BASKET LOCK COVER		
64	4	1083.00009.00	WASHER, #6 SCREW , INTL TOOTH LOCKWASHER		
65	2	1084.00010.00	NUT, HEX, #6-32, UNDERSIZED, ZINC PLATED		
66	4	1073.00016.00	LEG, THERMOPLASTIC, 2.50"(63mm)		
67	4	1073.00019.00	LEG, 3/8-16 THREAD x 1" LG., GRAY		
68	1	1086.00008.00	CONNECTOR, CLAMP, NON-METALLIC CABLE, 3/4"		
69	1	1003.00348.00	ADAPTER PLATE, CBS-1130-XV+, STRAIN RELIEF, CE		
70	1	1086.00029.00	BUSHING, STRAIN RELIEF, .360"-.430" DIA CABLE		
71	1	1044.00013.00	LABEL EQUIPOTENTIALITY, CE		
72	1	1052.00029.00	EMI FILTER, TWO LINE 20A, 120/250VAC		
73	2	1084.00012.00	NUT, HEX, #6-32 MACHINE SCREW		
74	1	1063.00016.00	POWER CORD, 120VAC W/NEMA 5-15P PLUG		
75	1	1063.00015.00	CORD, 120 VAC, 12/3 AWG ,20 AMP , W/5-20P NEMA PLUG		
76	1	1063.00032.00	CORD, POWER, NEMA 6-15P, 15A/250V, W/O TERMINALS		
77	1	1402.00039.11	HARNESS ADDITION, HIGH AMP, CBS-2231/41/51, UL		
78	1	1402.00121.10	WIRE HARNESS ADDITION, HIGH AMP, EMI FILTER, 2-POLE, CE		
79	1	1025.00142.00	TUBE, SILICONE, 3/4" OD X 1/2" ID X 3.75" LG, BREW		

CBS-2231 Tank Assembly-single heater

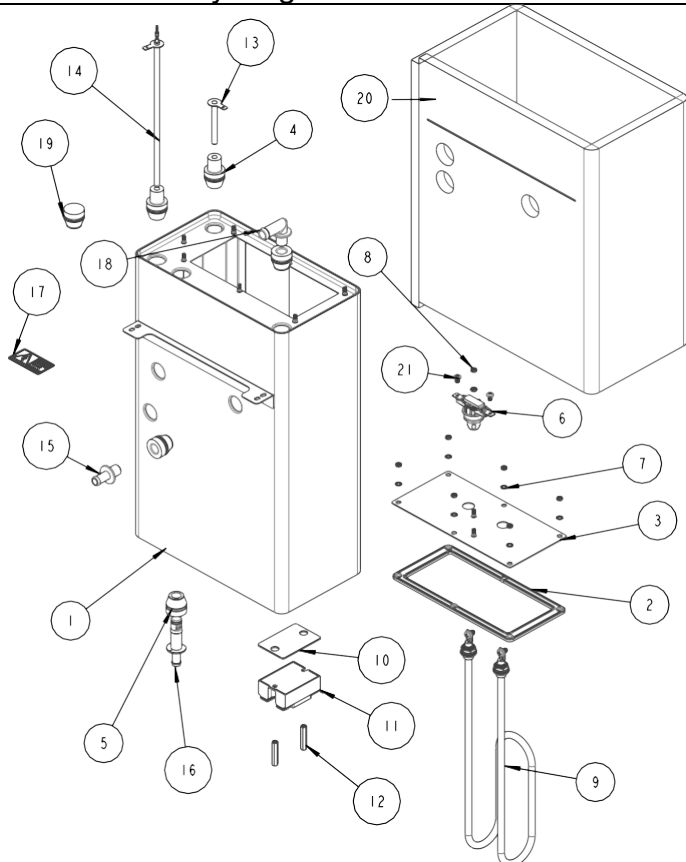

TANK ASSY, CBS-2231 Single Heater

Drawing number 1104.000169.00, 1104.000170.00, 1104.000172.00, 1104.000174.00, 1104.000175.00

REF	QTY	Part number	Description
1	1	1114.00168.001	WELDMENT, TANK, CBS-2231
2	1	1024.00114.00	TANK GASKET - NG HEATER PLATE, TWO ELEMENT
3	1	1114.00184.00	WELDMENT TANK HEATER BRACKET, NG-2231, SINGLE
4	2	1024.00053.00	LEVEL AND TEMP PROBE GROMMET
5	3	1024.00050.00	GROMMET, SILICONE, 11.4mm ID
6	1	1053.00052.00	THERMOSTAT, SINGLE SHOT, SCREW CONNECTIONS, 240V/25A
7	8	1083.00009.00	WASHER, #6 SCREW , INTL TOOTH LOCKWASHER
8	8	1084.00010.00	NUT, HEX, #6-32, UNDERSIZED, ZINC PLATED
9	1	1107.00021.00	HEATER ASSEMBLY, IMMERSION 1500W/120VAC
9	1	1107.00020.00	HEATER ASSEMBLY, IMMERSION 2300W/240VAC
9	1	1107.00019.00	HEATER ASSEMBLY, IMMERSION 2300W/120VAC
9	1	1107.00018.00	HEATER ASSEMBLY, IMMERSION 3000W/240VAC
10	1	1003.00140.00	ALUMINUM BRACKET FOR SSR
11	1	1052.00033.00	RELAY, SOLID STATE, 50A/480VAC, W/BUILD IN VARISTOR
12	2	1081.00042.00	STANDOFF, 1/4" HEX
13	1	1112.00002.00	PROBE WELDMENT, WATER LEVEL 2.25" LG
14	1	1102.00161.00	PROBE ASSEMBLY, TEMP. AND LLC, 8" LONG
15	1	1023.00168.00	FITTING, STRAIGHT, GROMMET, .400"
16	1	1023.00166.00	FITTING, COLD WATER INLET, GROMMET DESIGN
17	1	1044.00004.00	LABEL, DANGER, HIGH VOLTAGE
18	1	1023.00212.00	FITTING, ELBOW, GROMMET, .500"
19	1	1024.00051.00	GROMMET, SILICONE, BLANK
20	1	1022.00114.00	TANK INSULATION, CBS-2231
21	2	1082.00136.00	BRASS SCREW, #8-32 X 1/4", PHILLIPS PAN HEAD

Table of authorities for CBS-2231NG replacement hot water tank module-tank is sold complete with insulation

SKU Number. See page 3 for list	Description	Tank Part Number
E2231US-1A115-PA011	TANK , CBS-2231, 1 X 1.5KW/120VAC	1104.00169.00
E2231US-1A123-PA012	TANK , CBS-2231, 1 X 2.3KW/120VAC	1104.00172.00
E2231CE-1B123-PA015	TANK , CBS-2231, 1 X 2.3KW/240VAC	1104.00174.00
E2231NM-1B130-PA013; E2231CE-1B130-PA015	TANK , CBS-2231, 1 X 3.0KW/240VAC	1104.00175.00

CBS-2231 Tank Assembly-two heaters

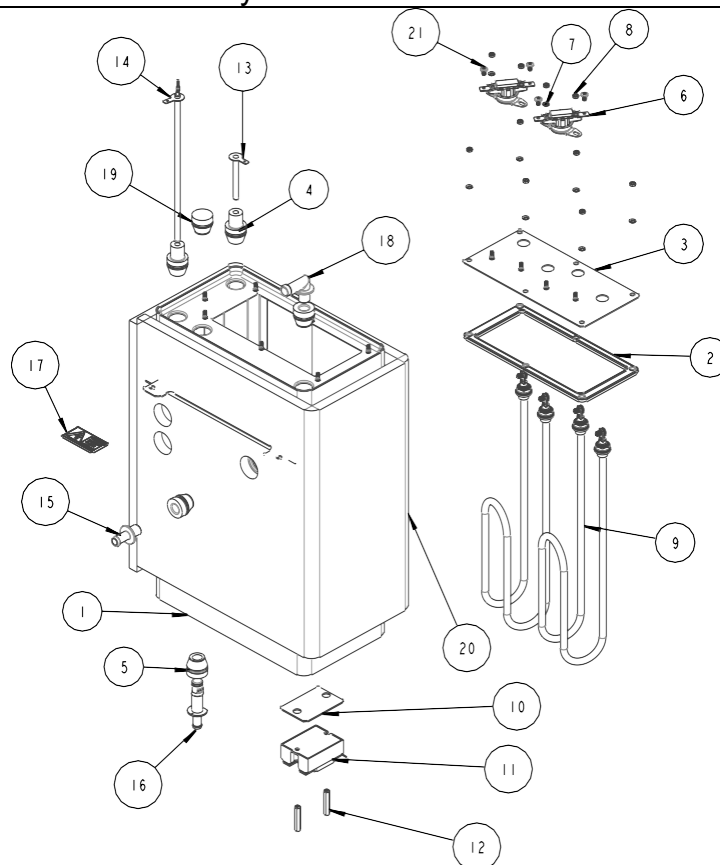

TANK ASSY, CBS-2231 Two Heater Drawing number 1104.000171.00, 1104.000173.00

REF	QTY	Part number	Description
1	1	1114.00168.00	WELDMENT, TANK, CBS-2231
2	1	1024.00114.00	TANK GASKET - NG HEATER PLATE, TWO ELEMENT
3	1	1114.00176.00	WELDMENT TANK HEATER BRACKET, NG-2231
4	2	1024.00053.00	LEVEL AND TEMP PROBE GROMMET
5	3	1024.00050.00	GROMMET, SILICONE, 11.4mm ID
6	2	1053.00052.00	THERMOSTAT, SINGLE SHOT, SCREW CONNECTIONS, 240V/25A
7	10	1083.00009.00	WASHER, #6 SCREW , INTL TOOTH LOCKWASHER
8	10	1084.00010.00	NUT, HEX, #6-32, UNDERSIZED, ZINC PLATED
9	2	1107.00022.00	HEATER ASSEMBLY, IMMERSION 1700W/120VAC
9	2	1107.00019.00	HEATER ASSEMBLY, IMMERSION 2300W/120VAC
10	2	1003.00140.00	ALUMINUM BRACKET FOR SSR
11	2	1052.00033.00	RELAY, SOLID STATE, 50A/480VAC, W/BUILD IN VARISTOR
12	4	1081.00042.00	STANDOFF, 1/4" HEX
13	1	1112.00002.00	PROBE WELDMENT, WATER LEVEL 2.25" LG
14	1	1102.00161.00	PROBE ASSEMBLY, TEMP. AND LLC, 8" LONG
15	1	1023.00168.00	FITTING, STRAIGHT, GROMMET, .400"
16	1	1023.00166.00	FITTING, COLD WATER INLET, GROMMET DESIGN
17	1	1044.00004.00	LABEL, DANGER, HIGH VOLTAGE
18	1	1023.00212.00	FITTING, ELBOW, GROMMET, .500"
19	1	1024.00051.00	GROMMET, SILICONE, BLANK
20	1	1022.00114.00	TANK INSULATION, CBS-2231
21	4	1082.00136.00	BRASS SCREW, #8-32 X 1/4", PHILLIPS PAN HEAD

Table of authorities for CBS-2231NG replacement hot water tank module-tank is sold complete with insulation

SKU Number. See page 3 for list	Description	Part Number
E2231NM-1X123-PA012, E2231NM-1A123-PA012	TANK CBS-2231, 2 X 2.3KW/120VAC	1104.00173.00
E2231US-1X117-PA011	TANK CBS-2231, 2 X 1.7KW/120VAC	1104.00171.00

CBS-2232 Tank Assembly

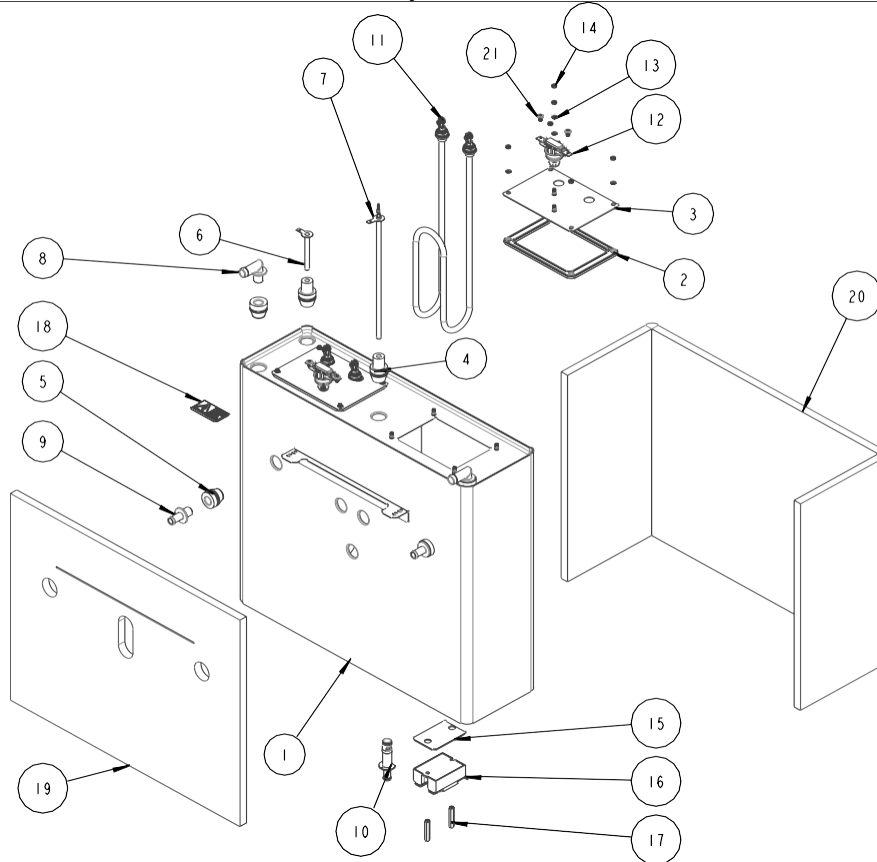

CBS-2232 Hot Water Tank Drawing 1104.00176.01

Ref#	Qty	Part number	Description
1	1	1114.00169.00	WELDMENT TANK CBS-2232, GROMMET DESIGN
2	2	1024.00115.00	TANK GASKET - NG HEATER PLATE, ONE ELEMENT
3	2	1114.00181.00	WELDMENT TANK HEATER BRACKET, NG-2232
4	2	1024.00053.00	LEVEL AND TEMP PROBE GROMMET
5	5	1024.00050.00	GROMMET, SILICONE, 11.4mm ID
6	1	1112.00002.00	PROBE WELDMENT, WATER LEVEL 2.25" LG
7	1	1102.00161.00	PROBE ASSEMBLY, TEMP. AND LLC, 8" LONG
8	2	1023.00212.00	FITTING, ELBOW, GROMMET, .500"
9	2	1023.00168.00	FITTING, STRAIGHT, GROMMET, .400"
10	1	1023.00166.00	FITTING, COLD WATER INLET, GROMMET DESIGN
11	2	1107.00019.00	HEATER ASSEMBLY, IMMERSION 2300W/120VAC
11	2	1107.00018.00	HEATER ASSEMBLY, IMMERSION 3kW/240VAC
11	2	1107.00040.00	HEATER ASSEMBLY, IMMERSION 4kW/240VAC
12	2	1053.00052.00	THERMOSTAT, SINGLE SHOT, SCREW CONNECTIONS, 240V/25A,
13	12	1083.00009.00	WASHER, #6 SCREW, INTL TOOTH LOCKWASHER
14	12	1084.00010.00	NUT, HEX, #6-32, UNDERSIZED, ZINC PLATED
15	2	1003.00140.00	ALUMINUM BRACKET FOR SSR
16	2	1052.00033.00	RELAY, SOLID STATE, 50A/480VAC, W/BUILD IN VARISTOR
17	4	1081.00042.00	STANDOFF, 1/4" HEX
18	1	1044.00004.00	LABEL, DANGER, HIGH VOLTAGE
19	1	1022.00113.00	TANK INSULATION, CBS-2232 FRONT
20	1	1022.00116.00	TANK INSULATION, CBS-2232 BACK
21	4	1082.00136.00	BRASS SCREW, #8-32 X 1/4", PHILLIPS PAN HEAD

Table of authorities for CBS-2232NG replacement hot water tank module-tank is sold complete with insulation

SKU Number. See page 3 for list	Description	Tank Part Number
E2232US-1B223-PA010, E2232US-1B223-MA110, E2232IN-1B223-PA010, E2232CE-1B223-PA010	TANK CBS-2232, 2 X 2.3KW/240VAC	1104.00176.00
E2232US-1B230-MA110, E2232US-1B230-PA010, E2232US-1B230-PA110, E2232IN-1B230-PA010, E2232IN-1B230-MA110, E2232NM-1B230-PA010 E2232CE-1B230-PA010	TANK CBS-2232, 2 X 3.0KW/240VAC	1104.00177.00

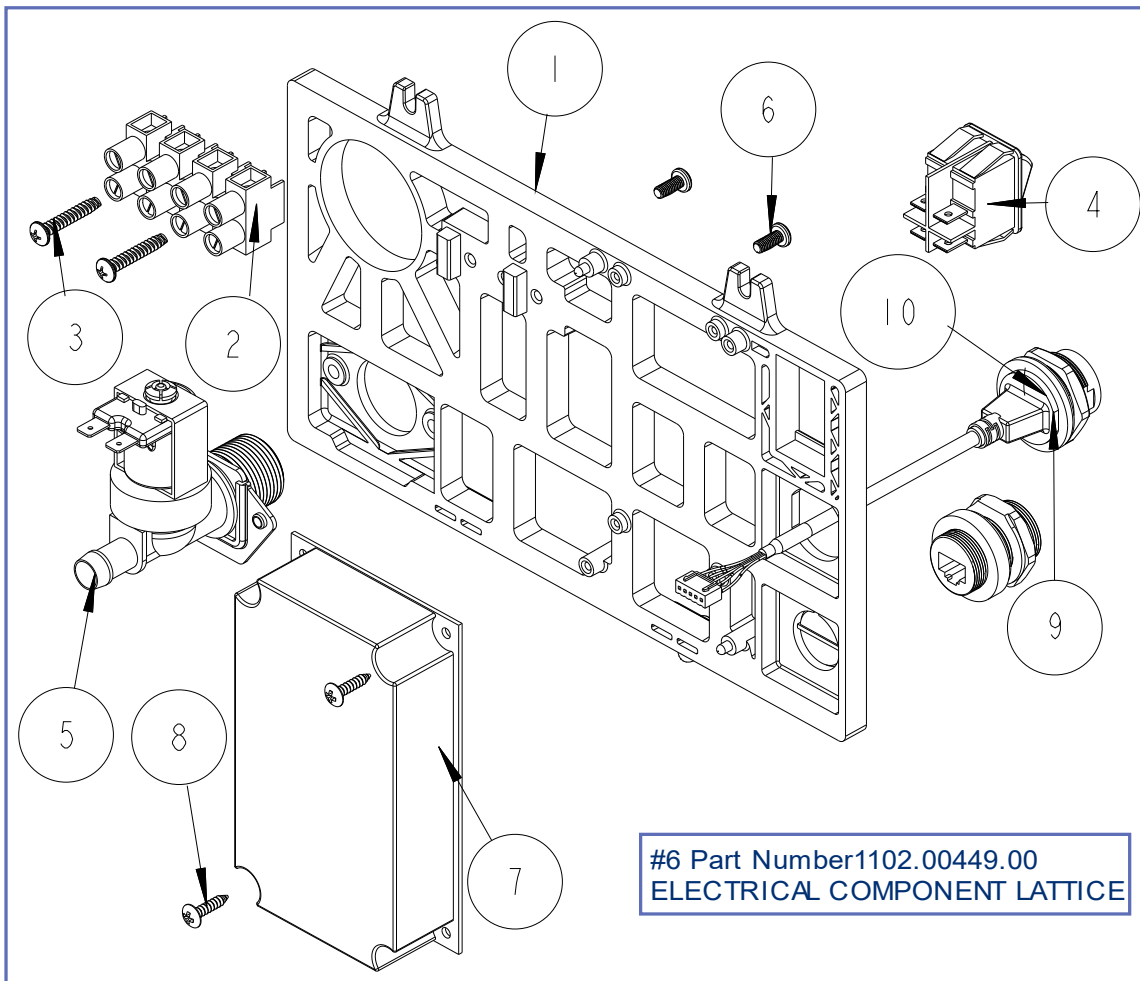

Ref	Qty	PartNumber	Description	Electrical component lattice, CBS-2200 Part#1102.00449.00
		1102.00449.00	COMPLETE ELECTRICAL COMPONENT LATTICE, CBS-2200	
1	1	1023.00350.00	ELECTRICAL MOUNTING LATTICE, COMMON	
2	1	1052.00023.00	EUROSTRIP HE16 TERM. BLOCK, 4 POLE, 63 AMP, 18-8 AWG	
3	2	1082.00056.00	SCREW, #8-11 X 1" PAN HD PHIL, THREAD FORMING	
4	1	1058.00024.00	SWITCH, POWER, DOUBLE POLE, 16A, 125/250 VAC	
5	1	1057.00043.00	SOLENOID VALVE, 5.5L/min, 180 DEG, 24VDC	
6	2	1082.00010.00	SCREW, PAN HD. PHIL. MACH., M4x10 ZINC-PLATED	
7	1	1052.00059.00	POWER SUPPLY, 90-264VAC/24VDC, 2.25A	
8	2	1082.00020.00	SCREW, #6 X 5/8, TRUSS HD PHIL, SHEET MTL	
9	1	1058.00055.00	USB CONNECTOR	
10	1	1058.00162.00	ETHERNET PLUG IN CONNECTOR, W/COVER	

Part number 1102.00451.00 Small Spray Assembly Parts-Quick connect version

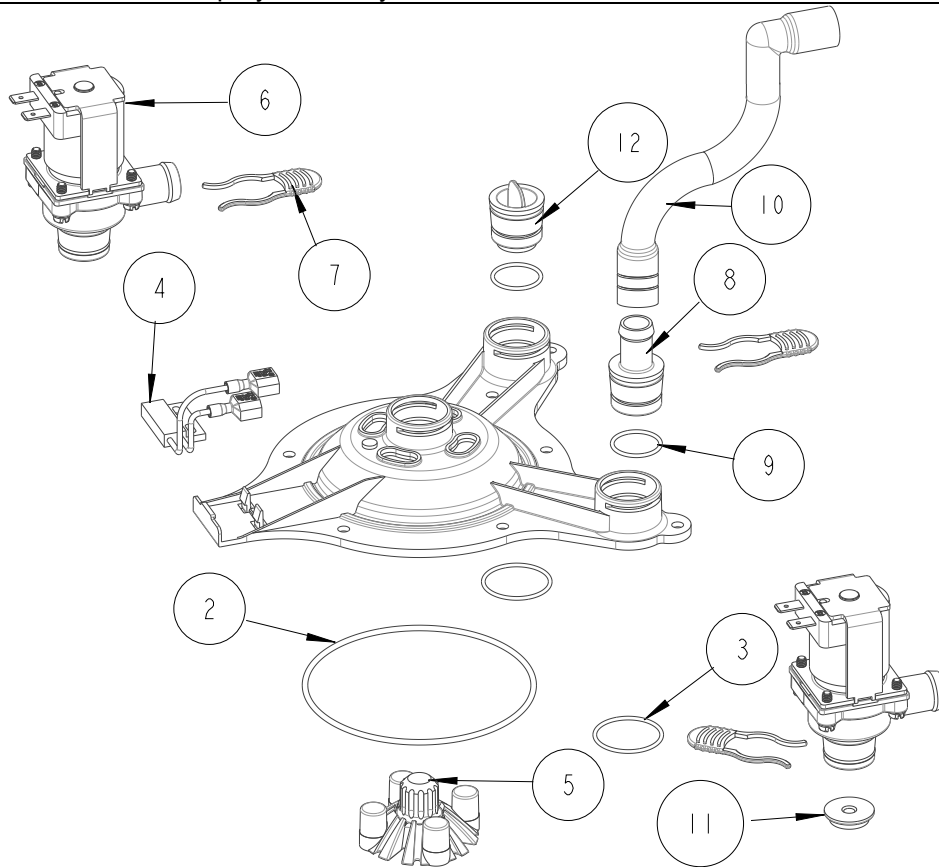

Ref#	Qty	Part number	Description
1	1	1000.00143.00	SPRAY HEAD BASE (KIT), QUICK CONNECT, 30/40'S
2	1	1024.00063.00	O-RING, 3 15/16" x 3/32" CS, DASH # 154, BUNA-N, DURO-A50
3	2	1024.00107.00	O-RING, 1 3/16" OD X 1 1/16" ID X 1/16" TH, BYPASS SEAL
4	1	1102.00113.00	SWITCH, REED, ASSEMBLY
5	1	1102.00479.00	ASSEMBLY, CASCADE SPRAY DOME, NEXT GEN, ORANGE
6	2	1057.00076.00	VALVE ASSEMBLY, COMPLETE, NG, DELTROL (interchangeable with 1057.00078.00)
6	2	1057.00078.00	VALVE ASSEMBLY, COMPLETE, NG, RPE (interchangeable with 1057.00076.00)
7	3	1023.00342.00	QUICK CONNECT CLIP
8	1	1023.00343.00	VENT INSERT, QUICK CONNECT
9	2	1024.00106.00	O-RING, 13/16"OD X 11/16"ID X 1/16" TH, FOR QUICK CONNECT
10	1	1024.00098.00	VENT TUBE, CBS- EXTRACTOR SERIES
11	1	1023.00369.00	ORIFICE INSERT, QUICK CONNECT, 3/16" HOLE
12	1	1023.00344.00	PLUG INSERT, QUICK CONNECT

Brew Baskets

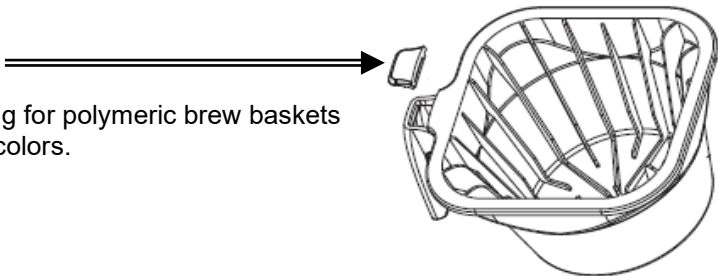
Plastic Brew Basket For CBS-2241 & CBS-2242		
Part Number B014218BN2BK – Complete Plastic Brew Basket 13" X 5", .218 DIA HOLE		
 <p>Brew basket handle plug for polymeric brew baskets is available in optional colors.</p>	Part Number	PLUG INSERT COLOR
	1023.00	BROWN PLUG, BB HANDLE
	195.00	BLACK PLUG, BB HANDLE
	1023.00	RED PLUG, BB HANDLE
	190.00	GREEN PLUG, BB HANDLE
	1023.00	ORANGE PLUG, BB HANDLE
	191.00	BLUE PLUG, BB HANDLE
	1023.00	192.00

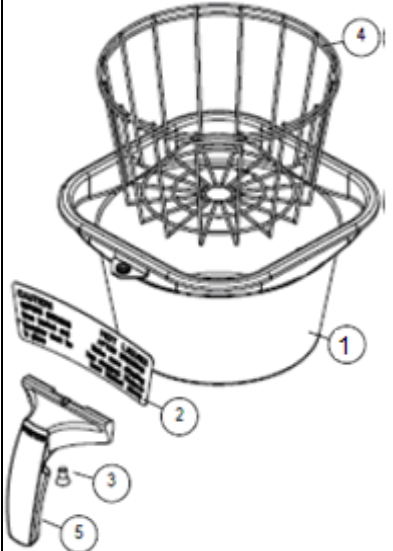
Stainless Steel Brew Basket For CBS-2241 & CBS-2242				
Part Number B003218B1 – Complete Stainless Steel Brew Basket 13" X 5", .218 DIA HOLE				
	Ref#	Qty	Part Number	Description
	1	1	1112.00128.00	BB WLDMNT 13" X 5", .218 DIA HOLE
	2	1	1046.00025.00	BREW BASKET WARNING LABEL
	3	1	1082.00040.00	SCREW, 1/4-20 X .5, FL HD, PH., W/NYLN
	4	1	1009.00006.00	WIRE BASKET
	5	1	1102.00064.00	HANDLE W/MAGNET ASY, BLACK
	Optional colored handle		1102.00065.00	HANDLE W/MAGNET ASY, RED
	Optional colored handle		1102.00066.00	HANDLE W/MAGNET ASY, GREEN
Optional colored handle		1102.00067.00	HANDLE W/MAGNET ASY, ORANGE	

Specialty Brew Baskets for Iced Tea/Tea and Specialty Coffee Brewing.

These brew baskets have reduced orifice sizes and may require PROGRAMMING changes to increase brewing time and pulses to enhance extraction and prevent basket overflow during steeping. Orifice reduction is not linear and might not be intuitive because the changes are in area (exponential as πr^2) Because the reduction is to surface area, the reduced diameter of the orifice can greatly affect (slow) the brew basket flow rate. This may cause the brew basket to overflow.

SEE Page 5- [Brew Recipes](#)

Stainless Steel				
Part Number	Orifice Size	% of Standard*	Handle Color	Filter Paper Size
B003218B1 (from above)	0.218-Sandard	100%	Black	13" X 5" or FETCO# F002
B003158B1	0.158	52%	Black	13" X 5" or FETCO# F002
B003110G1	0.110	25%	Green	13" X 5" or FETCO# F002
B003110B1	0.110	25%	Black	13" X 5" or FETCO# F002
B003079B1	0.079	13%	Black	13" X 5" or FETCO# F002
Plastic				
Part Number	Orifice Size		Plug Color	Filter Paper Size
B014218BN2BK (from above)	0.218-Sandard	100%	Black	13" X 5" or FETCO# F002
B014140G2BK	0.140	41%	Green	13" X 5" or FETCO# F002

Wiring Diagrams

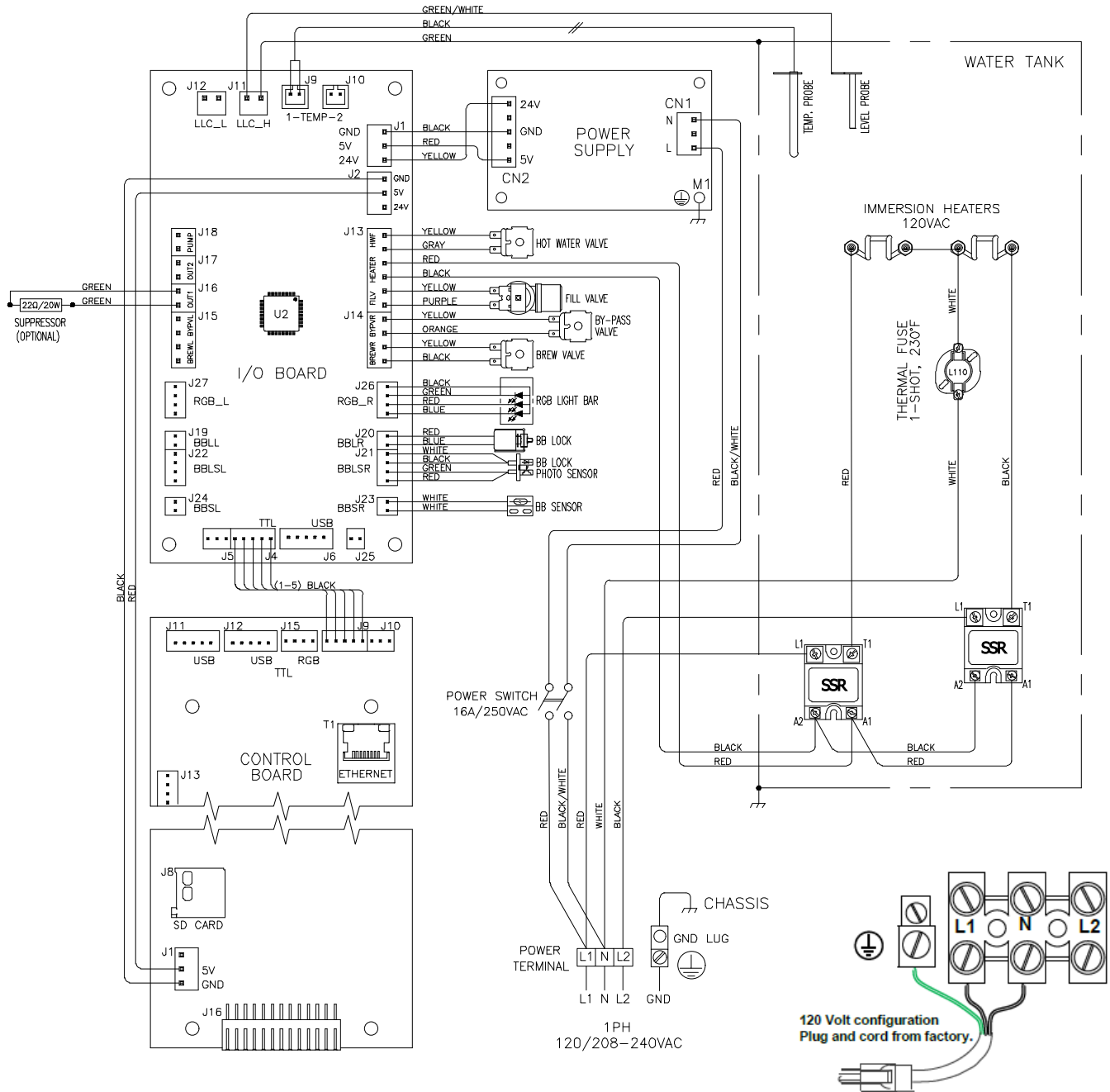

Wiring diagram 1401.00178.10 for the following SKU numbers-see page 3

E2231US-1X117-PA011 DUAL VOLT,	1Ph, 2+G/3+G, 2x1.7xw/120VAC, 120/208-240VAC,
E2231US-1A115-PA011 SINGLE VOLT	1Ph, 2+G, 1.5xw/120VAC
E2231US-1A123-PA012 SINGLE VOLT	1Ph, 2+G, 2.3xw/120VAC
E2231NM-1X123-PA012,NOM,DUAL VOLT,	1Ph, 2+G/3+G, 2x2.3xw/120VAC, 120/208-240VAC,
E2231NM-1A123-PA012,NOM, SINGLE VOLT	1Ph, 2+G, 2.3xw/120VAC
E2231NM-1B130-PA013, NOM, SINGLE VOLT	1Ph, 2+G, 3.0xw/240VAC
E2231IN-1B123-PA010 INTL, SINGLE VOLT	1Ph, 2+G, 2.3xw/240VAC
E2231IN-1B130-PA010 INTL, SINGLE VOLT	1Ph, 2+G, 3.0xw/240VAC

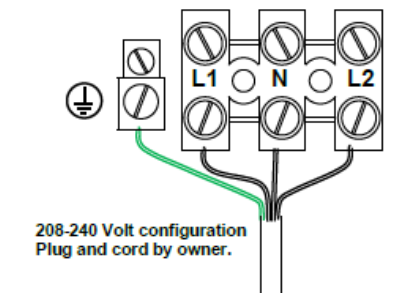

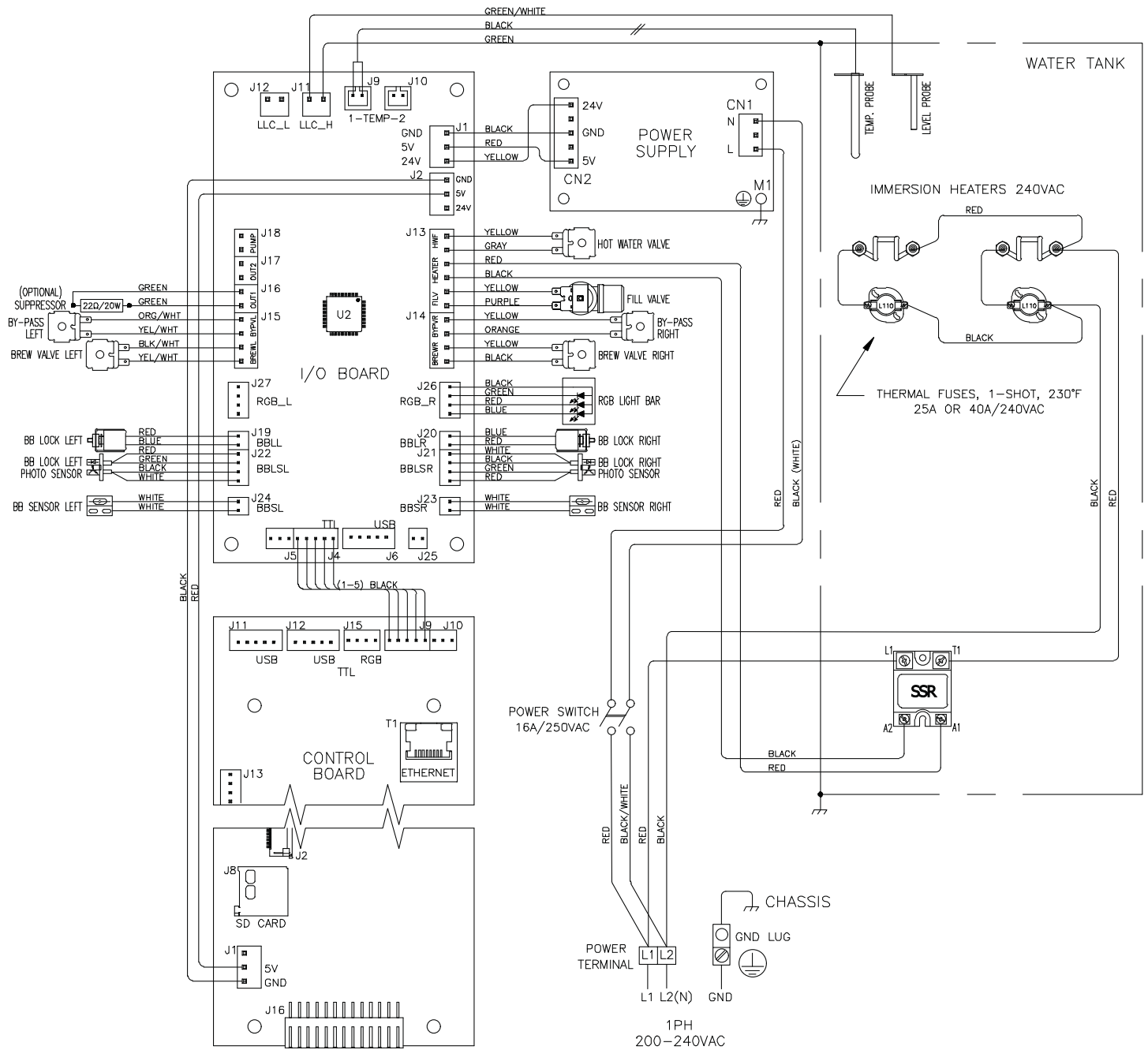

Wiring diagram for the following SKU numbers-see page 3

E2232US-1B223-PA010	CBS-2232, 1Ph, 2+G, 2x2.3kW/240VAC	Terminal Block
E2232US-1B230-MA110	CBS-2232, 1Ph, 2+G, 2x3kW/240VAC,	Terminal Block
E2232US-1B230-PA010	CBS-2232, 1Ph, 2+G, 2x3kW/240VAC,	Terminal Block
E2232US-1B230-PA110	CBS-2232, 1Ph, 2+G, 2x3kW/240VAC,	Terminal Block
E2232US-1B223-MA110	CBS-2232, 1Ph, 2+G, 2x2.3kW/240VAC,	Terminal Block
E2232IN-1B223-PA010	CBS-2232, INTL, 1Ph, 2+G, 2x2.3kW/240VAC,	Terminal Block
E2232IN-1B230-PA010	CBS-2232, INTL, 1Ph, 2+G, 2x3kW/240VAC,	Terminal Block
E2232IN-1B230-MA110	CBS-2232, INTL 1Ph, 2+G, 2x3kW/240VAC,	Terminal Block
E2232NM-1B230-PA010	CBS-2232, NOM, 1Ph, 2+G, 2x3kW/240VAC, ,	Terminal Block