

Single 1.0 Gallon Thermal Coffee Brewing System

CBS-51H10

CBS 5000
S E R I E S

The Ultimate Coffee Machine—in low profile Your Answer to Brewing The Best Tasting Coffee Consistently Day After Day...

Developed with proprietary designs and technologies, FETCO equipment ensures safety and integrity of each brew with innovative designs such as:

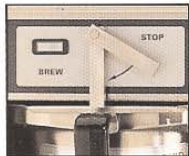

- Dual Brew Basket Safety Lock Incorporated Into Start Switch



- Brewing Directly Into Our Patented Luxus Dispenser To Ensure A Continuous Flow of Hot, Aromatic, Great Tasting Coffee

Fetco Brewers Utilize The Most Recent Technological Advances In Coffee Brewing In Order To:

- Hold A Constant Water Temperature During 100% Of Brew Cycle
- Maintain Sprayover Volume Consistency
- Resist Lime Buildup Inside Dispense Tube System
- Utilize All Solid State Components



The LUXUS Thermal Dispenser
Totally portable, requires no electric power.

Once filled and capped, it goes anywhere... Ready To Act As Your Remote Dispensing Station Wherever Needed

You can prepare them ahead of time and place them where you want them.

It is important to note that the LUXUS thermal dispenser can be staff-operated or used as a self-service system

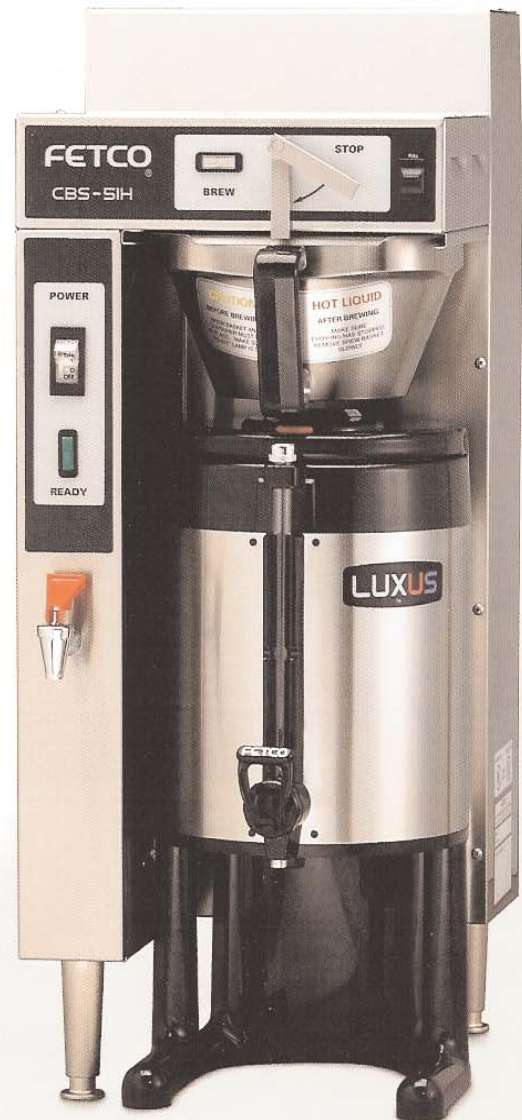

CBS-51H10 in Stainless Steel finish and with 1.0 Gallon LUXUS Dispenser

FETCO
CORPORATION

CBS-51H10

Standard Features:

- 1.0 Gal. Thermal, All Stainless Steel Lined Beverage Dispenser
- Stainless Steel Brew Basket, 13 x 5 inches
- Brew Basket Safety Lock
- Open Type, Leak Free Dispense System
- Fully Automatic With Electronic Temperature Control
- Mercury-Type Power Contactor
- Two-Level Water Tank Drain System
- Total Serviceability From The Front

Optional Features:

- Half Batch Brewing Capability
- Iced Tea Brewing Capability
- Color Stainless Steel Finish
- Custom & Export Voltage

Accessories:

- 1.0 Gallon Luxus Dispensers
- Single, Dual & Triple Serving Stations
- (for Luxus Server LS Models Only)
- Brewing Stand For Luxus Server LS Models

Dimensions & Specifications

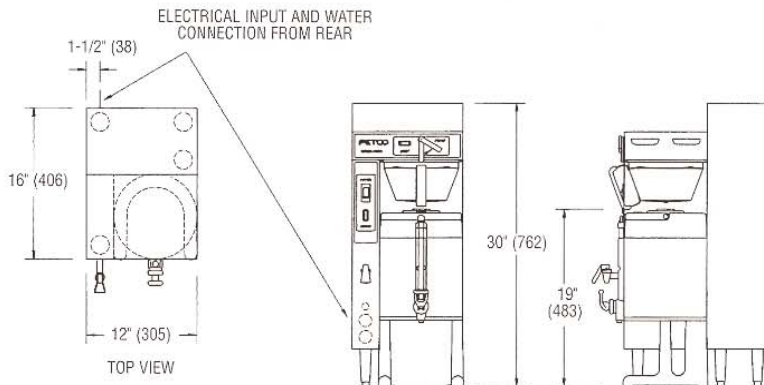

Water Requirements: 20-75 psig, 1/2 gpm flow rate. Water inlet is 3/8 Male Flare

Standard Electrical Configurations & Brewing Efficiency

Electrical Config. Code	Heater Configuration	Voltage	Phase	Wires	KW	Maximum Amp draw	Brews per Hour	
							Cold Water	Hot Water
CBS-51H10-1	1 x 1800 watt	120	1 ph	2 + ground	1.9	16.0	5.0	9.0
CBS-51H10-2	2 x 1800 watt	120/208-240	1 ph.	3 + ground	2.8 - 3.7	13.3 - 16.0	8.0 - 9.0	9.0
CBS-51H10-3	2 x 1800 watt	220	1 ph.	2 + ground	3.1	14.7	9.0	9.0

Weights & Capacities

MODEL	HEIGHT	WIDTH	DEPTH	BREWER EMPTY	BREWER FILLED	DISPENSER EMPTY	DISPENSER FILLED	BREWER & DISP FILLED	WATER TANK	DISPENSER	SHIPPING WEIGHT	CU. FT.
CBS 51H10	in/mm	in/mm	in/mm	lbs/kg	lbs/kg	lbs/kg	lbs/kg	lbs/kg	gal/l	gal/l	lbs/kg	ft/cu dec
	30/762	12/305	16/406	42/19.0	67/30.4	7.0/3.2	15.4/7.0	82.4/37.4	3.0/11.4	1.0/3.8	56/25.0	5.0/146

Patents & Approvals:

U.S. Pat. Nos. 5,000,082; 5,331,885. Other patents pending. LUXUS is a registered U. S. Trademark No.: 1797027



FETCO Corporation is a proud and active member of these organizations:



Food Equipment Technologies Company, Inc.
 640 Heathrow Drive, Lincolnshire, IL 60069 USA
 Phone: 847.821.1177 800-FETCO 99 Fax: 847.821.1178
 Internet: www.fetco.com E-mail: sales@fetco.com