

FETCO® User's Guide and Operator Instructions

CBS-2261, CBS-2262 Three Gallon Next Generation Brewing System FETCO Next Generation-NG® Commercial Beverage Equipment



CBS-2261

(Dispensers not included)



CBS-2262

(Stainless steel brew baskets are included with brewers)



CONTACT INFORMATION

FETCO® FOOD EQUIPMENT TECHNOLOGIES COMPANY

600 ROSE ROAD

LAKE ZURICH • IL • 60047-0429 • USA

Product made in USA

INTERNET: www.fetco.com

PATENTS: <https://www.fetco.com/pl/pages/patents,74.html>

©2020-2024 FOOD EQUIPMENT TECHNOLOGIES COMPANY



fetco.com

PHONE: (800) 338-2699 (US & CANADA)

(847) 719-3000 (All Countries and International)

FAX: (847) 719-3001

EMAIL: sales@fetco.com

orders@fetco.com (to order parts and equipment)

techsupport@fetco.com (all service queries)

P217 January 2024

COFFEE BREWER CBS-2260NG Series

TABLE OF CONTENTS

Specifications and Requirements	2	Calibration	11
Weights and Capacities	2	Calibrating flow rates	11
Rough-In Drawings	2	Outputs	12
Electrical and Output Specifications	3	Installation Guide	15
Programming Menu Layout.....	5	Operator Training.....	16
Brew Recipes	5	Parts diagrams.....	18
Settings	6	Wiring Diagrams	27
Inputs	7		

Specifications and Requirements

FETCO CBS-2260 Brewers have unique construction only available for these models.

Water Requirements:		Coffee Filter Size: 20" X 8" – standard FETCO # F004 18" X 7½" - optional half batch FETCO # F005 For optional brew basket B00828003
CBS-2260 20-75 psig, (138-517kPa) 1½ gpm/(5.7 lpm)		
Water inlet fitting: 3/8 inch male flare.		Temperature, as set by factory: 200°F (93°C) inside water tank (at sea level)
Optimal water hardness between 125-250 TDS (6-13 grain) Important! Please use a water filter for all beverage equipment		
Electrical: See electrical configuration chart Pg 3.		
Brew Volume: Full Batch 3 gal. (11.4 lit.) All batches are user configurable		
Brew Capacity (approximate)	CBS-2261 5-8 brews per hour CBS-2262 5-20 brews per hour	Output is controlled by heater power and water temperature
Total Brew Cycle: Factory setting: 6 minutes consisting of 4 min. brew time and 2.0 min. drip delay		
Individual menu brew-process parameters are user controllable for:		
Basic user controls for brew volume, brew time, units of measure, recipe name		
Advanced user controls for pulse count, prewet percent and prewet delay, drip delay, programmable energy saving		

Weights and Capacities

Model	Height	Width	Depth	Water tank capacity	Empty Weight	Filled Weight	Shipping Weight	Shipping Dimensions
CBS-2261 3 gal	41.38" 105.11 cm	17.88" 45.42 cm	27.50" 69.85 cm	8.6 gallon 33 L	88 lbs 39.9 kg	160 lbs 72.6 kg	97 lbs 44.0 kg	39" x 23" x 28" 99 x 58.4 x 71.7 cm
CBS-2262 3 gal	41.38" 105.11 cm	32.0" 81.28 cm	27.50" 69.85 cm	15.9 gallon 60 L	130 lbs 59.0 kg	266 lbs 120.7 kg	140 lbs 63.5 kg	39" x 37" x 29" 99 x 94 x 73.7 cm

Rough-In Drawings

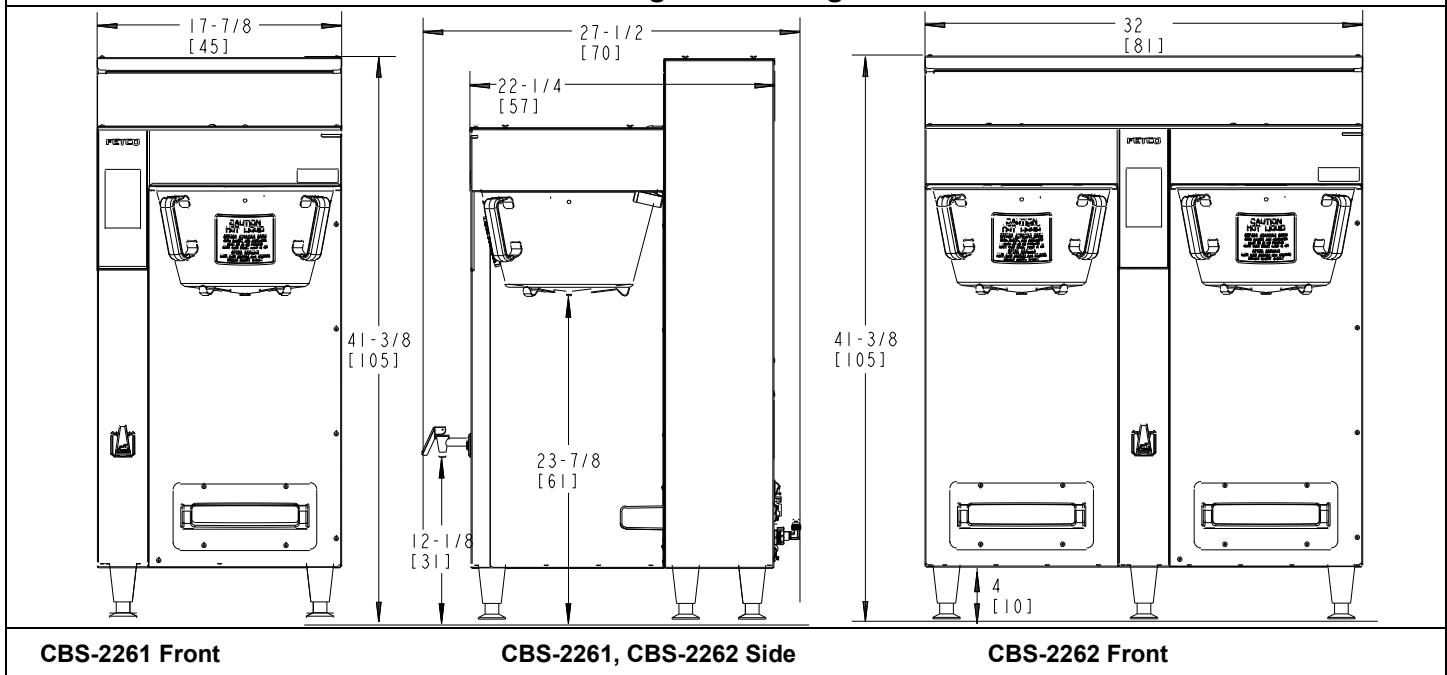

EXAMPLE: SKU E2261US-UB230-MA110																
SKU NUMBER IDENTIFICATION KEY																
Product Line	Level		Family		Region ID		Phase	Voltage Range	# Heaters	Individual Heater Wattage		Brew Basket	Hot Water Faucet	Bypass	Brew Basket Locks	Power Cord
E	2	2	5	3	U	S	U	B	2	5	0	P	M	01	1	0
E=extractor					US =United States		1		1			P=plastic	M=manual	1=Yes	1=Yes	0=Terminal Block
			61=	3	IN =		2	B = 200-240	2			M=metal	A=automatic	0=no	0=no	1= NEMA 5-15P
		22=Next Gen Series	62=		CE = CE		3	C = 380-415	3				N=None			2=NEMA 5-20P
					NM = NOM		U = 1 or 3	D = 440-480			3.0					3=NEMA 6-15P
											4.0					4=NEMA 6-30P
								X=120 or 240 Dual Voltage	6		5.0					5= CEE 7/7 Schuko
																6=UK1-13P
																7= AUSTRALIAN

Electrical and Output Specifications							
CBS-2261 <i>Next Generation</i> Single 3 Gallon-11.4 Liter Coffee Brewers							
CBS-2261 Domestic USA and Canada models				Single-Voltage. With cUL/UL & NSF-4 Certification			
Electrical and Output Specifications All brewers use terminal block electrical connection for 50Hz or 60Hz Professional installation is required							
SKU Number	Phase	Voltage	Heater Configuration	Wires	KW	Amp Draw	Brew-Volume Per Hour
E2261US-UB230-MA110 Field Selectable 1 or 3 phase Sold as 3 phase	1	200-240	2 X 3.0kW	2+G	4.6-6.1	21.2-25.8	15.9 gal/16.4 L
	3	200-240	3 X 3.0kW	3+G	6.9-9.1	18.6-22.5	23.9gal/90.6 L
*Sold as three phase, highest power version Equipment may be field configurable to single phase, lower-power, single-phase configuration using two heaters.							
CBS-2261 Domestic and International models				Single-Voltage. With cUL/UL & NSF-4 Certification			
Electrical and Output Specifications All brewers use terminal block electrical connection for 50Hz or 60Hz Professional installation is required							
E2261IN-3C330-MA110	3	220/380 or 240/415	3 X 3.0kW	3L/N/G	7.6-9.1	11.7-12.7	23.9 gal/90.6 L
E2261IN-3C340-MA110	3	220/380 or 240/415	3 X 4.0kW	3L/N/G	10.2-12.1	15.5-16.9	30.0 gal/114 L
E2261IN-3C350-MA1101	3	220/380 or 240/415	3 X 5.0kW	3L/N/G	12.7-15.1	19.3-21.0	30.0 gal/114 L
CBS-2261 NOM (Mexico In Spanish)				Single-Voltage. With cUL/UL & NSF-4 Certification			
Electrical and Output Specifications All brewers use terminal block electrical connection for 50Hz or 60Hz Professional installation is required							
E2261NM-3B350-MA110	1	208-240	2 X 3.0kW	3+G	11.3-15.0	31.8-36.6	30.0 gal/114 L
CBS-2261 Export CE				CE listed models with NSF-4 Certification. Internal EMI Filter		Not cUL or UL Listed	
Electrical and Output Specifications All brewers use terminal block electrical connection for 50Hz or 60Hz Professional installation is required							
E2261CE-3B330-MA110	3	230/400	3 X 3.0kW	3L,N,PE	8.3	12.5	22.1 gal/83.6 L
E2261CE-3B340-MA110	3	230/400	3 X 4.0kW	3L,N,PE	11.0	16.5	29.2 gal/111 L
NM in SKU suffix (above) denotes equipment with NOM certification, Spanish labeling for Mexico and Spanish language user guide							

Electrical and Output Specifications for CBS-2262 <i>Next Generation</i> Dual 1½ Gallon-6 Liter Coffee Brewers							
CBS-2262 Domestic USA and Canada				Single-Voltage. With cUL/UL & NSF-4 Certification			
Electrical and Output Specifications All brewers use terminal block electrical connection for 50Hz or 60Hz Professional installation is required							
SKU Number	Phase	Voltage	Heater Configuration	Wires	KW	Amp Draw	Brew-Volume Per Hour
E2262US-3B330-MA110	3	208-240	3 x 3.0 kW	3+G	6.8-9.0	19.3-22.2	23.9 gal/90.6 L
E2262US-3B630-MA110	3	208-240	6 x 3.0 kW	3+G	13.5-18.0	38.0-43.8	47.8 gal/181 L
E2262US-3B340-MA110	3	208-240	3 x 4.0 kW	3+G	9.0-12.0	25.5-29.4	31.9 gal/121 L
E2262US-3B640-MA110	3	208	6 x 4.0 kW	3+G	18.0	50.5	47.8 gal/181
CBS-2262 NOM (Mexico In Spanish)				Field Selectable-Voltage. With cUL/UL & NSF-4 Certification			
Electrical and Output Specifications All brewers use terminal block electrical connection for 50Hz or 60Hz Professional installation is required							
E2262NM-3B630-MA110	3	208-240	6 x 3.0 kW	3+G	13.5-18.0	38.0-43.8	47.8 gal/181 L
NM in SKU suffix (above) denotes equipment with NOM certification, Spanish labeling for Mexico and Spanish language user guide							

Customer options	BREW BASKET TYPE (P, M OR C)	HOT WATER FAUCET (M, A OR N)	BYPASS (1 OR 0)	Brew Basket Lock (1 OR 0)
* is factory standard feature Add all the following numbers after all SKU numbers	*P=Plastic M=Gourmet Metal C= Gourmet Metal + clips	*M=Standard manual A=Automatic electronic N=No hot water faucet	*1=With 0=None	*1=With 0=None

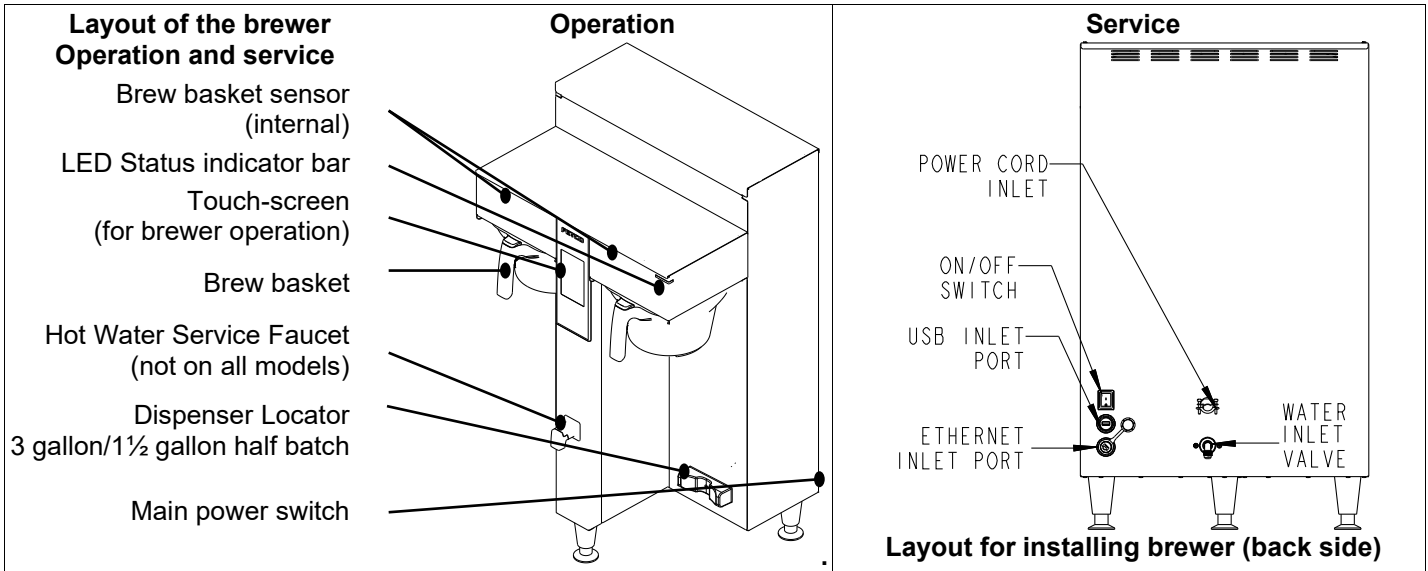

TOC		
Starting The Brew		
	<ol style="list-style-type: none"> Turn the power switch "ON". (Twin Shown) Prepare a brew basket with the correct size filter and appropriate amount of coffee. (6-12 ounces or 170-340 grams for 1½ gal/6 liters) Slide the brew basket completely into the rails. Place a clean, empty, preheated dispenser under the brew basket. Select a batch & touch the corresponding BREW icon (Batch #1 selected in illustration), then press "START" -STOP icon will illuminate, -Countdown time will display, with proportional graphic circle icon -LED indicator will pulse. -All other BREW icons for that brew head will be hidden.-Opposite side BREW icons on dual brewer remain active When the brew cycle is finished, -Spray icon will extinguish and the BREW circular icon will remain. This indicates that coffee may still be dripping from the brew basket For safety- do not remove brew basket until drip-out is complete. 	
Twin Brewer ready to brew. Batch one-top left brew position selected		Brewing in process Batch one selected

Programming		
<p>To enter programming</p> <ol style="list-style-type: none"> Turn the power switch "OFF", then "ON": Bootup will begin <p>Tap the logo screen - after the bootup screen disappears (logo screen shown on right→)</p>	<ol style="list-style-type: none"> "Enter Password" screen appears Operator password is 1,2,3,4: Note: For general use <p>Service password is 9,8,7,6 Note: Do not distribute this number (shown right→)</p>	<ol style="list-style-type: none"> Make changes and adjustments from the Programming Menu screen (Shown right→) <p>See programming menu layout next page</p>
<p style="text-align: center;">Bootup screen</p>	<p style="text-align: center;">Password Screen</p>	<p style="text-align: center;">Programming access</p>

CBS-2200NG Next Generation

Programming Menu Layout

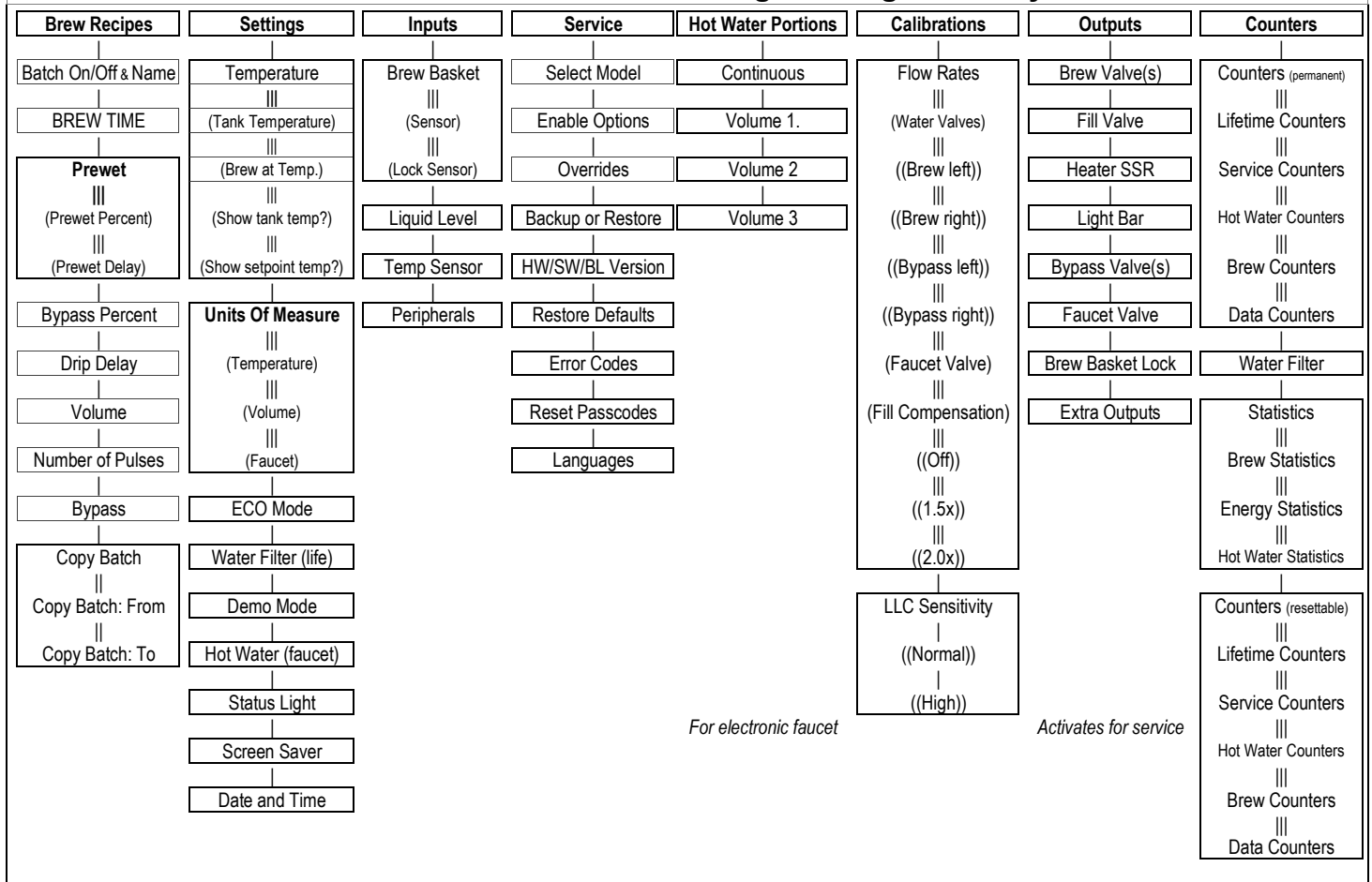

For electronic faucet

Activates for service

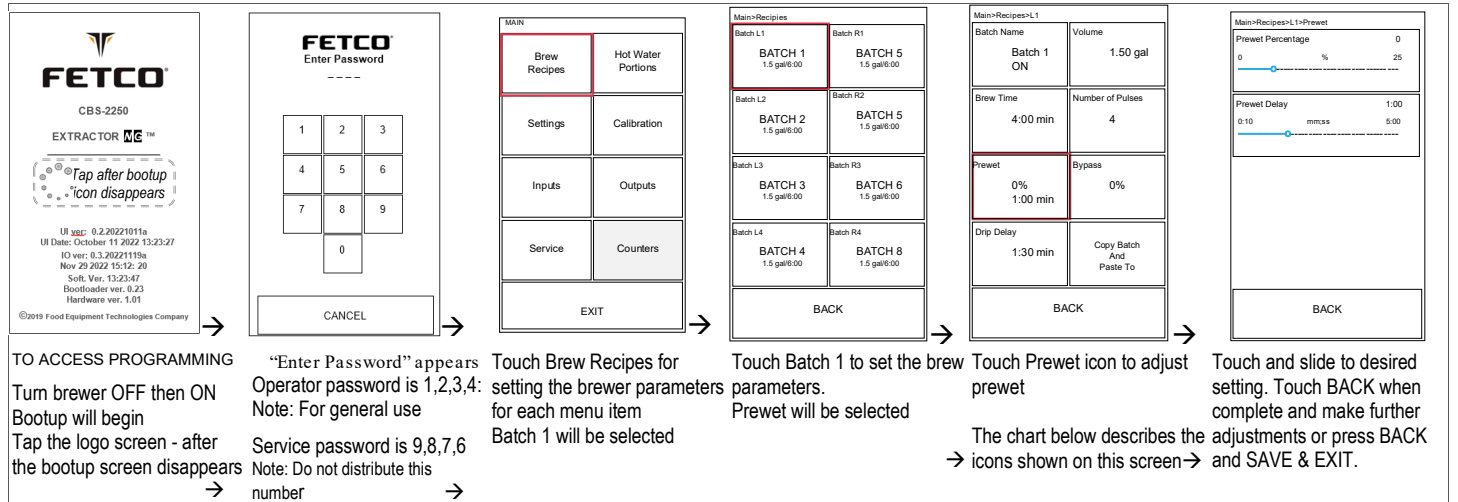

Brew Recipes	Program Items	Factory set Default	Programming Range	Notes
Batch Name	Batch On/Off	All “ON”	On/Off	Only top batch(s) are always enabled
Batch Name	Customize Name	Batch (1-4 L) (5-8 R)	Complete keypad	Scroll and tap three virtual keypads
Brew Time	Time of brew	4:00 minutes	2:00-12:00 mins/secs	Add to prewetting and drip delay times
Prewet	Prewet percentage	0	0-25% brew volume	Initial wetting to stabilize very fresh coffee
Prewet	Prewet delay time	1:00 sec.	0:10 sec to 5:00 min	Pause after coffee bed is prewettted
Drip Delay	Pause after brew	2:00 min:sec.	00.30 to 6:00	Time that brew basket remains locked during drip-out. This is a safety feature.
Brew Volume	Total volume	1.5 gallons/5.6 liters 1.0 gallon/3.8 liter 2.0 gallons/8liters	0.5-2.0 gal./0.95-8.0 liters	Factory set for 1½ gallon dispenser and for 1 gallon second batch
Number of Pulses	Start/stop in brew	8	4-20	Algorithm evenly divides brew time cycle
Bypass Percentage	Diverts brew water	0	0-40% of brew volume	Affects flavor, strength and mouth-feel
Copy & Paste Menu	Current recipe		Paste into all other recipes	Will paste selected into the other

Inputs	Program Items	Factory set Default	Programming Range	Notes
Brew Basket	Sensor	Displays activity	Brew basket in place?	LEFT <input type="radio"/> RIGHT <input type="radio"/> (green=on;red=off)
Brew Basket	Lock Sensor	Displays activity	Brew basket locked?	LEFT <input type="radio"/> RIGHT <input type="radio"/> (green=on;red=off)
Liquid Level	LOW	Not used	Not used	Not used
Liquid Level	HIGH	Hot water tank fill	Filled/Not Filled & signal	Green=Filled/Red=Not Filled
Temp. Sensors	Sensor 1	Hot water tank temp.	Actual temperature & signal	
Temp. Sensors	Sensor 2	Not used	Not used	Not used
Peripherals	USB1	Digital input/output	Displays activity	(green=active;red=off)
Peripherals	USB2	Not used	Not used	Not used
Peripherals	RS-232	Digital input/output	Displays activity	(green=active;red=off)

Service	Program Items	Factory set Default	Programming Range	Notes
Select Model	Set brewer model	CBS-2242	MODEL (single side) 1 (dual side) 2 223x <input type="radio"/> 224x <input type="radio"/> 225x <input type="radio"/> 226x <input type="radio"/>	To select: touch icon for brewer, touch "BACK" and got to EXIT & SAVE
Enable Options			Options Electric HW faucet <input type="checkbox"/> OFF <input type="checkbox"/> ON Bypass Valve(s) <input type="checkbox"/> OFF <input type="checkbox"/> ON Brew Basket Lock(s) <input type="checkbox"/> OFF <input type="checkbox"/> ON Expansion Board <input type="checkbox"/> OFF <input type="checkbox"/> ON	
Overrides	Brew Basket Sensor Brew Basket Lock Brew Basket Lock Sensor HW Press and hold		Override Safety Features Left Right Brew Basket Sensor <input type="checkbox"/> OFF <input type="checkbox"/> ON <input type="checkbox"/> OFF <input type="checkbox"/> ON Brew Basket Lock <input type="checkbox"/> OFF <input type="checkbox"/> ON <input type="checkbox"/> OFF <input type="checkbox"/> ON Br. Basket Lock Sensor <input type="checkbox"/> OFF <input type="checkbox"/> ON <input type="checkbox"/> OFF <input type="checkbox"/> ON HW Press and hold <input type="checkbox"/> OFF <input type="checkbox"/> ON <input type="checkbox"/> OFF <input type="checkbox"/> ON	Overriding deactivates onboard safety systems. This is not recommended for normal operation. A warning/reminder will display in the start screen
Backup or Restore	Backup current configuration	Will save all programmed settings	Requires USB thumb drive	Insert USB thumb drive and touch "BACKUP" & follow instructions
Backup or Restore	Installs saved settings	USB thumb drive with one file-	One file, must be titled: backup.txt	Insert USB thumb drive and touch "RESTORE" & follow instructions
HW/SW/BL Version			Software UI 0.2.221011a IO 0.3.20221119a Bootloader UI Bootloader IO Compilation Time UI Oct 11 2022 13:28:09 IO Nov 29 2022 15:12:20 Hardware Main Board rev IO Board rev	
Restore Defaults	Return factory sets		Will overwrite all settings	Touch and hold icon 5 seconds
Error Codes			Error Log Error Code → Code & definition Date/time stamp Export Log To USB Follow prompts to export Error Statistics Error code frequency Error Statistics Follow prompts to delete	
Reset Passcodes	Overrides default		Operator Code Follow prompts to change Service Code Follow prompts to change	
Languages	Reserved for future use			

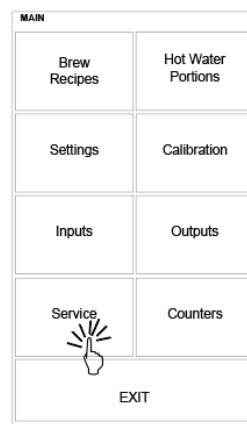
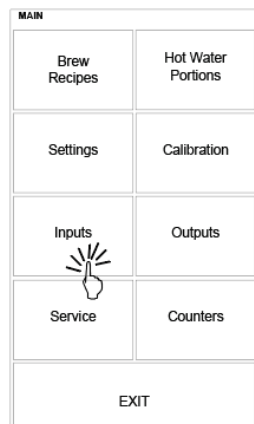

Error Codes (From SERVICE – Page7)			
DO NOT CLEAR ERROR CODES UNTIL ERROR IS IDENTIFIED AND CORRECTED			
→Contact factory or specialized personnel for error codes			
Code	Description	Possible Cause	Corrective Action
001	Software error-error on start up or corrupted software	Improper start-up or shutdown	Restart, if still fault: reload software
002	Internal flash corrupted internal data memory malfunction	Error found in cyclic redundancy check CRC	Restart, if still fault: reload software If not corrected: replace board
010	Front U/I board loses communication with the interior O/I board	No communication between front panel	Cycle brewer Off then On. Check cable connections
011	Front U/I board bad communication with the interior O/I board	Disrupted communication Cable connections loose	Cycle brewer Off then On. Check cable connections
Error codes 10 and 11 may be generated by loose connections, electronic interference, or a software/bootloader issue. For assistance by email: open the SERVICE menu and go to the HW/SW/BL Version. Send a cellphone picture of this screen to techsupport@fetco.com with the serial number of the equipment and your return phone number. For live service, write down the screen information or have the HW/SW/BL Version available and contact FETCO by phone at (800) 338-2699 option 2) to discuss with Technical Service. (Email support is usually faster) The correction for ERROR 10 or 11 may require a simple Off/On power cycle or a bootloader/firmware update that can be sent by email. Contact FETCO as above if cycling power or connections do not correct the fault.			
050	Short-circuit in temperature probe	Probe failure.	Replace probe.
051	Open temperature probe.	Bad probe connection, or probe failure.	Check all connections. Replace probe if necessary.
100	Initial Fill Error. Initial fill time took longer than expected after powering up.	Water supply flow rate is too low, fill valve is stuck, water line kinked or closed.	Reboot machine. If persists-investigate cause of low flow rate. (Clogged water filter, kinked line, stuck fill valve)
101	Error on refill- Tank did not refill within expected time.	Water supply flow rate to hot water tank is too low, or fill valve stuck or damaged (SEE PAGE 14)	Check water supply line. Flow should be 20-75 psig, (138-517kPa) >1gal/3.8L/min Investigate cause of low flow rate. If the flow rate is in range-replace fill valve
200	Heating flatline-Tank is boiling	Heater is on, temperature is not rising/dropping	High elevation correction. Bad heaters or temperature probe or position
201	If the hot water tank heaters are turned on during a heating cycle and tank temperature is not increasing according to software logic and the tank temperature is below setpoint	1) Failure of SSR, high limit, temperature probe, or heating element. 2) Water being removed by hot water faucet during heating (control displays "heating")	1)Test and check SSRs, high limit devices temperature probe. Check heating elements with current clamp, replace if necessary. 2)Advise staff to refrain from taking large amounts of water from hot water tank, especially during "heating".
202	Heater Shorted or Stuck SSR	Heater is off and heating SSR is stuck "ON"	Check ohms on heater (15-60Ω). SSR may be stuck in ON mode-replace SSR.
255	Keyboard [HID] error (<u>H</u> uman <u>I</u> nterface <u>D</u> evice)	Usually from longer than 10 seconds' contact. Or faulty reassembly after service	Restart, if still fault: reload software. If mechanical: replace module
NO BSKT <u>Insert Brew Basket</u>			Brew basket must be in place This is a SAFETY FEATURE
Insert brew basket into brewer rails to enable brewer			

Hot Water Portions	Program Items	Factory set Default	Programming Range	Notes
This setting is only for brewers with an electronic hot water faucet. In the <u>SETTINGS</u> menu, the "Automatic" feature must be enabled				
Hot Water Portions	Enabled	"ON"		OFF/ON
Hot Water Portions	Name	Continuous	Rename on keypad	Scroll and tap three virtual keypads
	Safety Timeout	0:25	0:10 min 0:60 -----○----- Scroll and go to EXIT&SAVE	Sets limit for touch and dispense
Hot Water Portions	Volume 1	6 oz.		
	Enabled	ON	Turns "ON" or "OFF"	OFF/ON
	Name	Volume 1	Rename on keypad	Scroll and tap three virtual keypads
	Volume dispensed	6 oz	Volume 6 2 oz 30 -----○----- Scroll and go to EXIT&SAVE	Sets limit for #1 touch and dispense
Hot Water Portions	Volume 2	8 oz		
	Enabled	ON	Turns "ON" or "OFF"	OFF/ON
	Name	Volume 2	Rename on keypad	Scroll and tap three virtual keypads
	Volume dispensed	8 oz	Volume 8 2 oz 30 -----○----- Scroll and go to EXIT&SAVE	Sets limit for #2 touch and dispense
Hot Water Portions	Volume 3	8 oz		
	Enabled	ON	Turns "ON" or "OFF"	OFF/ON
	Name	Volume 3	Rename on keypad	Scroll and tap three virtual keypads
	Volume dispensed	12 oz	Volume 12 2 oz 30 -----○----- Scroll and go to EXIT&SAVE	Sets limit for #3 touch and dispense

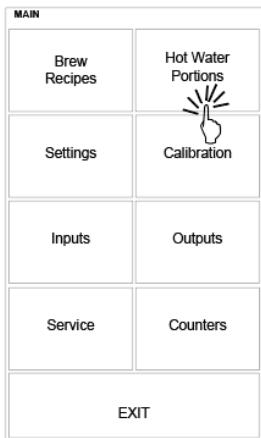

Calibration	Program Items	Factory set Default	Programming Range	Notes
Flow Rates Water Valves	Brew left	3500 ml/min	Brew Left 1.05 (Gal.)/3550 (ml) 3350 ml/min 4650 0.88 gal/min 1.22 -----○-----	Use to attenuate and compensate for variations in brew valve output
Flow Rates Water Valves	Brew right	3500 ml/min	Brew Right 1.05 (Gal.)/3550 (ml) 3350 ml/min 4650 0.88 gal/min 1.22 -----○-----	Use to attenuate and compensate for variations in brew valve output
Flow Rates Water Valves	Bypass left	2500 ml/min	Bypass Left 0.67(Gal.)/2500 (ml) 2100 ml/min 2950 0.55 gal/min 0.77 -----○-----	Use to attenuate and compensate for variations in bypass valve output
Flow Rates Water Valves	Bypass right	2500 ml/min	Bypass Right 0.67(Gal.)/2500 (ml) 2100 ml/min 2950 0.55 gal/min 0.77 -----○-----	Use to attenuate and compensate for variations in bypass valve output
Flow Rates Faucet Valve	For automatic hot water faucet	1500 ml/min 50 oz/min	Faucet Valve 50(oz)/1500(ml) 500 ml/min 5000 16 oz/min 169 -----○----- Scroll and go to EXIT&SAVE	To compensate variations in timed dispense from automatic hot water faucet
Fill Compensation	Slow Flow Compensation	OFF	○ Off ○ .. 1.5x ○ 2.5x Scroll and go to EXIT&SAVE	Use for FloJet bottled water supply or for reduced water supply from mains.
LLC		NORMAL	○ Normal ○ .. High Scroll and go to EXIT&SAVE	Liquid level control sensitivity. Normal for most water. High is for reverse osmosis water or very pure water.

Calibrating flow rates Correcting over and under batch volumes

MAIN	MAIN	MAIN-Outputs- Brew	MAIN	MAIN-Calibration	MAIN-Calibration-Flow	MAIN-Calibration-Flow-Valves																																																						
<table border="1"> <tr><td>Brew Recipes</td><td>Hot Water Portions</td></tr> <tr><td>Settings</td><td>Calibration</td></tr> <tr><td>Inputs</td><td>Outputs</td></tr> <tr><td>Service</td><td>Counters</td></tr> <tr><td colspan="2">EXIT</td></tr> </table>	Brew Recipes	Hot Water Portions	Settings	Calibration	Inputs	Outputs	Service	Counters	EXIT		<table border="1"> <tr><td>Brew Valve(s)</td><td>Bypass Valve(s)</td></tr> <tr><td>Fill Valve</td><td>Faucet Valve</td></tr> <tr><td>Heater SSR</td><td>Brew Basket Lock</td></tr> <tr><td>Light Bar</td><td>Extra Outputs (RESERVED)</td></tr> <tr><td colspan="2">EXIT</td></tr> </table>	Brew Valve(s)	Bypass Valve(s)	Fill Valve	Faucet Valve	Heater SSR	Brew Basket Lock	Light Bar	Extra Outputs (RESERVED)	EXIT		<table border="1"> <tr><td>Left</td><td>Right</td></tr> <tr><td>Brew</td><td></td></tr> <tr><td colspan="2">BACK</td></tr> </table>	Left	Right	Brew		BACK		<table border="1"> <tr><td>Brew Recipes</td><td>Hot Water Portions</td></tr> <tr><td>Settings</td><td>Calibration</td></tr> <tr><td>Inputs</td><td>Outputs</td></tr> <tr><td>Service</td><td>Counters</td></tr> <tr><td colspan="2">EXIT</td></tr> </table>	Brew Recipes	Hot Water Portions	Settings	Calibration	Inputs	Outputs	Service	Counters	EXIT		<table border="1"> <tr><td>Flow Rates</td><td>Display</td></tr> <tr><td>LLC</td><td></td></tr> <tr><td colspan="2">BACK</td></tr> </table>	Flow Rates	Display	LLC		BACK		<table border="1"> <tr><td>Water Valves</td><td>Faucet Valve</td></tr> <tr><td>Fill Valve</td><td>Fill Compensation</td></tr> <tr><td colspan="2">BACK</td></tr> </table>	Water Valves	Faucet Valve	Fill Valve	Fill Compensation	BACK		<table border="1"> <tr><td>Brew Left Valve 3950(ml)/1.05(Gal.) 3350 ml/min 4650 -----○-----</td></tr> <tr><td>Brew Right Valve 3450(ml) 3350 ml/min 4650 -----○-----</td></tr> <tr><td>Bypass Left Valve 2500(ml) 2100 gal/min 2950 -----○-----</td></tr> <tr><td>Bypass Right Valve 0.67(Gal.) 0.55 gal/min 0.77 -----○-----</td></tr> <tr><td colspan="2">BACK</td></tr> </table>	Brew Left Valve 3950(ml)/1.05(Gal.) 3350 ml/min 4650 -----○-----	Brew Right Valve 3450(ml) 3350 ml/min 4650 -----○-----	Bypass Left Valve 2500(ml) 2100 gal/min 2950 -----○-----	Bypass Right Valve 0.67(Gal.) 0.55 gal/min 0.77 -----○-----	BACK	
Brew Recipes	Hot Water Portions																																																											
Settings	Calibration																																																											
Inputs	Outputs																																																											
Service	Counters																																																											
EXIT																																																												
Brew Valve(s)	Bypass Valve(s)																																																											
Fill Valve	Faucet Valve																																																											
Heater SSR	Brew Basket Lock																																																											
Light Bar	Extra Outputs (RESERVED)																																																											
EXIT																																																												
Left	Right																																																											
Brew																																																												
BACK																																																												
Brew Recipes	Hot Water Portions																																																											
Settings	Calibration																																																											
Inputs	Outputs																																																											
Service	Counters																																																											
EXIT																																																												
Flow Rates	Display																																																											
LLC																																																												
BACK																																																												
Water Valves	Faucet Valve																																																											
Fill Valve	Fill Compensation																																																											
BACK																																																												
Brew Left Valve 3950(ml)/1.05(Gal.) 3350 ml/min 4650 -----○-----																																																												
Brew Right Valve 3450(ml) 3350 ml/min 4650 -----○-----																																																												
Bypass Left Valve 2500(ml) 2100 gal/min 2950 -----○-----																																																												
Bypass Right Valve 0.67(Gal.) 0.55 gal/min 0.77 -----○-----																																																												
BACK																																																												
Enter PROGRAMMING Then Touch "OUTPUTS"	Touch "BREW VALVES" to calibrate Brew Valve	Place calibrated Touch "RIGHT" and hold for exactly 60 seconds Carefully measure the water dispensed and retain this number. Here the volume was <u>3450</u> (Short potting)	TOUCH "BACK" Twice Touch "CALIBRATION"	Touch "FLOW RATES"	Touch "WATER VALVES"	Enter the retained number (3450) into the slider for the Right Brew Valve. Brewer automatically corrects flow rate.																																																						

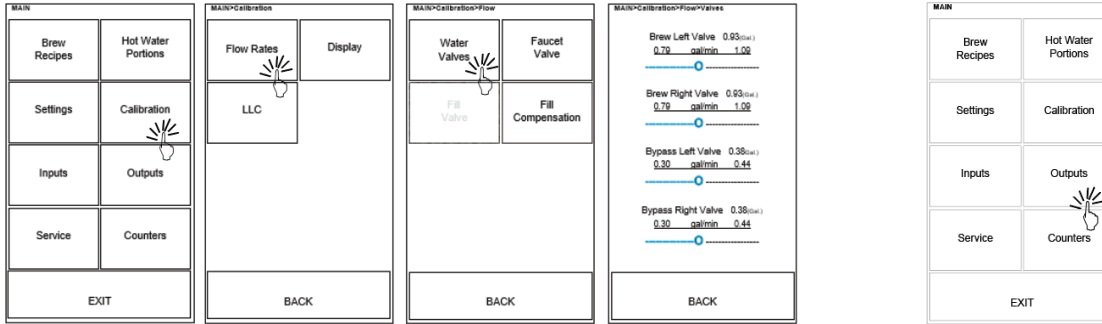

PROGRAMMING sequence for calibrating left brew valve from page 10

Enter into OUTPUTS-below

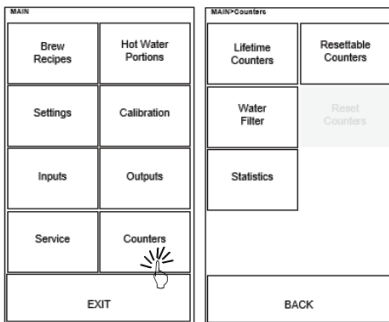

Outputs	Program Items	Factory set Default	Programming Range	Notes
These settings are used to activate individual controls for testing verifications and servicing operations				
Brew Valve(s)	Momentarily operate Left or Right Brew valves		Brew Left Right	Have dispenser under spray head! Touch to activate flow
Fill Valve	Momentarily operate fill valve		Fill	Have dispenser under spray heads! Touch to activate flow
Heater SSR	Turns on all heaters		Heater 3 sec max	Activates SSRs to turn on heaters
Light Bar	Momentarily operate light bar(s)		Status Light	
Bypass Valve(s)	Momentarily operates Left or Right Bypass valves		Bypass Left Right	Have dispenser under bypass port! Touch to activate flow
Faucet Valve	Momentarily operate faucet valve	For brewers with automatic hot water faucet	Faucet	Have dispenser under faucet! Touch to activate flow
Brew Basket Lock	Operates brew basket locks, toggling them on and off		BBL lock Left Right BBL Unlock Left Right BBL Sensor Left Right	Will toggle brew basket locks to be engaged then OFF.
Extra Outputs	For future use	Not used	Not used	Not used



Counters	Program Items	Factory set Default	Programming Range	Notes
This setting shows usage of the brewers functions				
Lifetime Counters	Service Counters		Main>Counters>Lifetime>Service Lifetime Counters (units in hours and liters) Unit Uptime 0 Fill Valve Volume 0 Activation 0 Heater Time On 0 Activation 0 Hot Water Dispense Count 0 Hot Water Valve Volume 0 Activation 0 Brewer Volume 0 Left Right Brew Count 0 0 Brew Valve Volume 0 0 Activation 0 0 Bypass Valve Volume 0 0 Activation 0 0 Locks Activation 0 0	
	Hot Water Counters		Main>Counters>Lifetime>Faucet Lifetime Counters (units in liters) Volume Activation Continues 0 0 1 0 0 2 0 0 3 0 0	
	Brew Counters		Main>Counters>Lifetime>Brew Lifetime Counters (units in liters) Recipe Number Activation Volume 1 0 0 2 0 0 3 0 0 4 0 0 5 0 0 6 0 0 7 0 0 8 0 0	
	Data Counters	Reserved for future		
Water Filter	Water Filer Life Time		Main>Counters>Reset Filter Water Filter Life Time Filter Life Time 0% of 10,000 Press and hold button for 5 seconds To Reset Filter 	
Statistics	Brew Statistics	Reserved for future		
	Energy Statistics	Reserved for future		
	Hot Water Statistics	Reserved for future		
Resettable Counters	Service Counters	See screen above	Main>Counters>Reset>Clear	Clear Resettable Counters Press and hold button for 5 seconds To Clear Error Log 
	Hot Water Counters	See screen above		
	Brew Counters	See screen above		
	Service Counters	See screen above		

Brewer Setup

1) Attach legs

NOTE-Assemble legs immediately after unpacking the brewer and before connecting it to utilities

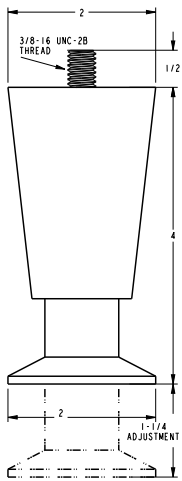

NOTE-Legs are located in brew basket

4" legs -

Part number 1073.00007.00
3 required for CBS-1262
4 required for CBS-1261

Always attach legs before installing.
Legs are sent from factory inside brew basket.

2) Verify dispenser locator

Reversible dispenser locator is user configurable
From TPD-30 (3 gal) To L4D-15 or TPD-15 (1 1/2 gal)

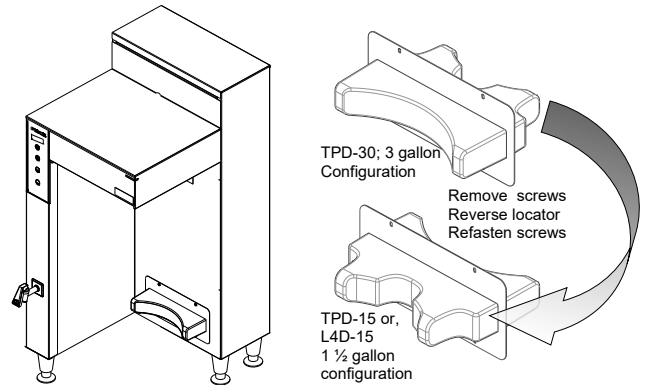

3) Attach water inlet adapter

Place rubber washer with screen in adapter. Hand tighten only-and 1/4 turn with wrench

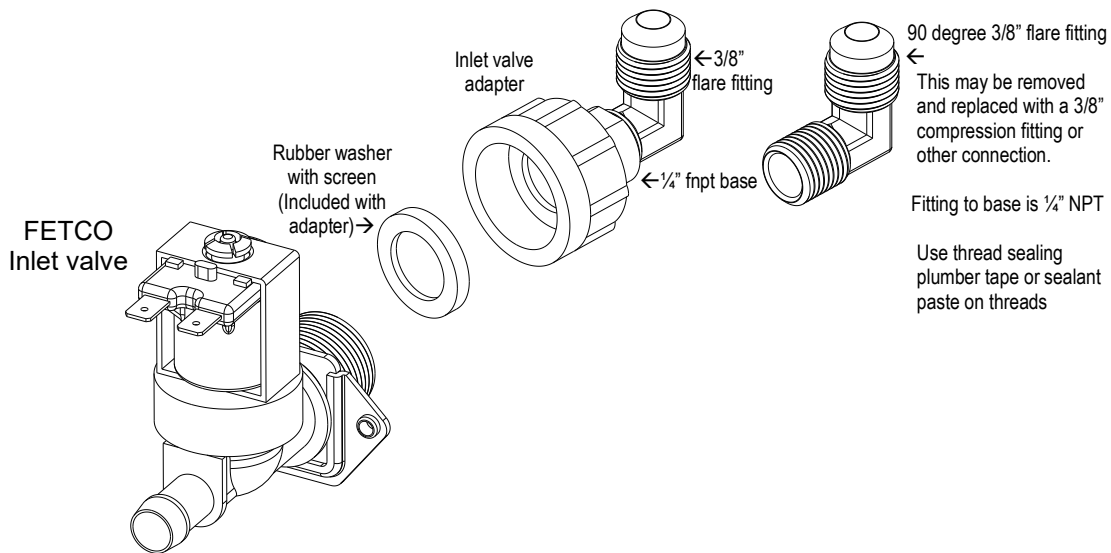

Install the adapter on inlet valve first before attaching water line. Adapter is shipped in the brew basket
The valve threads are 3/4" BSP MALE THREAD and are not 3/4" garden hose fittings.
Use of any other connector to valve will damage the valve
DO NOT use USA dishwasher water adapter or USA washing machine adapter for this connection.
The threads on these USA adapters are unusable for the valve

TO PREVENT DAMAGE AND INSURE PROPER EQUIPMENT OPERATION

The inlet valve thread is 3/4 INCH BSP (British Standard Pipe).

This valve is not a standard USA washing machine or dishwasher thread (3/4" GHT)

-Use only the plumbing adaptor kit included with this equipment. Use the gasket included in adaptor kit

-Plumber's tape is not recommended for the adapter to valve connection

-Hand tighten adapter on valve with gasket, then very lightly wrench 1/4 turn to set

-DO NOT SUBSTITUTE FITTINGS FOR CONNECTING TO WATER SUPPLY

Damage to inlet valve from improper installation will void the warranty

NOTE: DO NOT PLUMB TANK DRAIN. DRAIN IS FOR SERVICE AND MAINTENANCE.

Installation Guide

(For Qualified Service Technicians Only)

General:

1. If not installed correctly by qualified personnel, the brewer will not operate properly and damage may result.
2. Utilize only qualified beverage equipment service technicians for service and installation.
3. Always have an empty dispenser under spray head of all coffee brewing equipment-including when at idle
4. Damages resulting from improper installation are not covered by the warranty, and will void the warranty.
5. Attach the legs to the brewer before attaching the power and water lines. **See Page 12.**

Electrical:

1. All FETCO brewers require **an electrical ground wire**. Installation without grounding is dangerous.
2. Note Equipotentiality Terminal, if present, (To identify the terminals which, when connected together, bring the various parts of equipment or of a system to the same potential, not necessarily being the earth (ground) potential, e.g. for local bonding.)
3. Verify voltages, polarity, circuits, and circuit breaker access before attaching equipment.
4. Brewers in this series wire differently in regards to a neutral wire. Review the wire diagrams.
5. The electrical diagram is located in the User's Guide and online at www.fetco.com.
6. Make sure of the tight grounding of the equipment and use the external ground bolt.
7. The installation must comply with applicable federal, state, and local codes having jurisdiction at your location. Check with your local inspectors to determine what codes will apply.

→See wiring diagrams for connections

Plumbing:

1. North America: All installations must comply with applicable federal, state, or local plumbing codes.
2. All Others: The water and waste piping and connections shall comply with the International Plumbing Code 2003, International Code Council (ICC), or to the Uniform Plumbing Code 2003 (IAPMO).
3. Use an inline water filter for all beverage equipment.
4. Install the filter unit after a water shutoff valve and in a position to facilitate filter replacement.
5. The water line and newly installed filter cartage must be flushed thoroughly prior to connecting it to the brewer to prevent debris from contaminating the machine.
6. Verify that the water line will provide a flow rate of at least 1½gpm/(5.7lpm) per minute and the water pressure is between 20-75 psig (138-517kPa) before making any connections.
7. **See page 12** about using only the factory fitting when connecting the incoming water line.
8. Install a backflow prevention device. Most municipalities require a recognized backflow preventer. Usable on all hot beverage and cold beverage equipment is a WATTS® SD-2 or SD-3.



WATTS spring loaded double check valve models are accepted by most zoning authorities.

→The check valve should be as close to the water supply inlet of the beverage equipment as possible.

Tank Drain

The water tank must be drained before maintenance procedures, and when the unit is to be relocated or shipped

1. Disconnect power and water to unit. DANGER: Insure that all utility connections to the brewer are broken.
2. Move the unit near a sink or obtain a container large enough to hold four gallons of water.
→Note: the hot water tank may hold more than four gallons.
3. Remove the front panel and tank cover and allow the tank to cool to a safe temperature
4. The tank drain line and clamp are located inside-under the hot water tank. Pinch the drain line clamp to close
5. Locate the fill valve against the back wall, using pliers, loosen the hose clamp and move it back over the tube.
→Note Do not loosen the hose clamp to the bottom of the hot water tank
6. Crimp the tube an inch or two away from the drain plug to prevent water from flowing and pull it off the valve.
7. Pull the tube end out of the brewer and position over sink or bucket.
8. Release the crimped tube and hose clamp and allow the water to flow into the sink or container.
9. Multiple buckets may be needed during the draining, see tank volumes below.

Brewer	Hot Water Tank Capacity	OPEN Leave open for use	
CBS-2261 Single	6.3 gal 24 liter		
CBS-2262 Twin	11.5 gal 44 liter	PINCH SHUT To drain tank & service brewer	

Operator Training

Review the operating procedures with whoever will be using the brewer.

Pay particular attention to the following areas:

1. Always pre-heat the dispensers before the first use of each day by filling them half way with hot water, and letting them stand for at least 5 minutes.
2. Do not remove the brew basket from a coffee brewer until it has stopped dripping.
3. Make sure the dispenser is empty before brewing into it.
4. Show how to attach covers, close, and or secure the dispensers for transporting.
5. Show the location and operation of the water shut off valve as well as the circuit breaker for the brewer.
6. Steam from the tank will form condensation in the vent tubes. This condensation will drip into and then out of the brew baskets. Up to 1/4 cup/60 cc discharging overnight is possible. Place an appropriate container under each brew basket when not in use.
7. We recommend leaving the power to the brewer on overnight. The water tank is well insulated and very little electricity is used to keep the tank hot. Leaving the brewer in the "ON" position will also avoid delays at the beginning of shifts for the brewer to reach operating temperature.

Cleaning & Maintenance

After Each Brew:

1. Dispose of grounds and rinse brew basket.
2. Never strike a brew basket or hit it against a hard surface.
This will damage the brew cone, and may damage the brew basket support rails
3. Rinse dispensers before reuse.

Every Day:

1. Wash brew basket with hot sudsy water.
2. Pull CSD from the spray head, it is magnetically attached. Use gloves or a heavy towel. → Wash off any film and reattach. Use vinegar if limescale filming is present.
3. Clean dispensers with hot suds water and a brush, rinse and air dry.
4. Use only a soft cloth and hot suds on the outside to avoid scratches. Never use abrasives that will scratch surface.

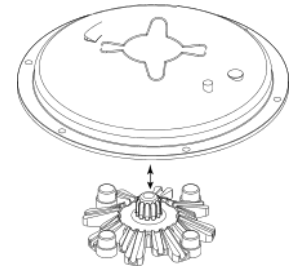

Weekly

1. Use a commercial coffee dispenser cleaner such as URNEX™, TABZ™, DIP-IT™ or Squeak 'n Clean™.
2. Carefully Follow the instructions supplied with the cleaning product
3. Never use spray cleaners, solvent, solvent based cleaner or petroleum based polish anywhere on dispensers

Warning

1. Turn off power before any cleaning procedure, including wiping the exterior for appearance reasons.
2. Dry the exterior, especially the face panel, before turning on power.
3. Do not apply any type of spray cleaner on the face panel of this equipment.
4. Never use solvent or solvent-based cleaner or petroleum based polish anywhere on this equipment.
5. Dry the face of the touch pad before turning on power
6. Do not electrically energize this equipment or attempt operation without all covers in place and all screws fastened.
7. Unplug machine before disassembly or servicing.

Installation safety and hygiene directions-For International and CE equipment

1. Access to the service area is restricted to persons having safety/hygiene knowledge and practical experience of the coffee brewer. This appliance must be installed in locations where it can be overseen by trained personnel.
2. For proper operation, this appliance must be installed indoors where the temperature is between 10°C/50°F to 35°C/95°F. Drain and remove all liquid from equipment and lines if exposed to freezing temperatures.
3. All commercial cooking equipment, including this unit, is not intended for use by children or persons with reduced physical, sensory, or mental capabilities. Ensure proper supervision of children and keep them away from the unit.
4. Children should be supervised to ensure that they do not play hot beverage equipment.
5. This unit must be installed and serviced by qualified personnel only.
6. Installation must conform to all local electrical and plumbing codes. Installation by unqualified personnel will void the unit warranty and may lead to electric shock or burn, as well as damage to unit and/or its surroundings.
7. If the power cord requires repair or replacement-it must be performed by the manufacturer or authorized service personnel with the specified cord only from the manufacturer in order to avoid a hazard.
8. Review the dimensions for the unit and verify that it will fit properly in the space intended for it. Verify that the counter or table will support the total weight of the brewer and dispensers when filled (See: Technical Data).
9. Place the brewer on the counter or stand. When the brewer is in position, level it front to back as well as side-to-side by adjusting the legs.
10. Note that the rewers will need a sturdy supported surface for operation. Do not move brewers when filled.
11. Do not tilt appliance more than 10° to insure safe operation.
12. Unit is for protected indoor use only. Do not steam clean or use excessive water on unit.
13. This unit is not "jet-proof" construction. Do not pressure wash or use jet spray to clean this unit.
14. The unit is not waterproof-do not submerge or saturate with water.

**Equipment exposed to flood and contaminated must not be used due to electrical and food safety.
Do not operate if unit has been submerged or saturated with water.**

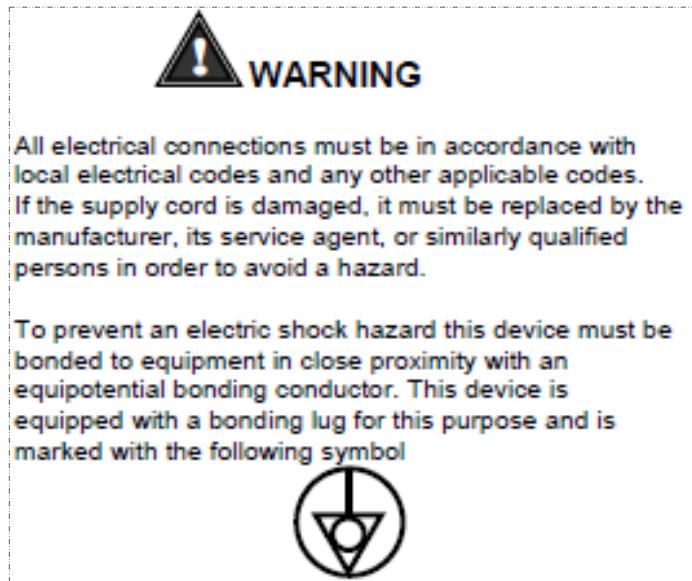

Labels and warnings for hot beverage equipment

	WARNING To reduce risk of electric shock or fire.
	FETCO® Hot Beverage Equipment is for commercial use only.
	Do not remove or open cover. No user serviceable parts inside. Refer installation and service to qualified personnel.
	Caution, disconnect from power supply before servicing.
	GROUND: National Electrical Code requires separate grounding wire.
	Use dedicated circuit with capacity rated by local code or National Electrical Code for the current draw of this equipment. Check serial number plate on right side for power requirements.
	Locate unit away from source of heat. Do not install or use near combustibles.
	THIS APPLIANCE IS ENERGIZED WHENEVER IT IS CONNECTED TO A POWER SOURCE
	FAILURE TO COMPLY RISKS EQUIPMENT DAMAGE, PROPERTY DAMAGE, FIRE, OR SHOCK HAZARD
	This equipment must be installed with a backflow protection device to comply with federal, state or local municipality codes.
	Read the user guide before installing and operating this unit.

Label for BACK PANEL of equipment (1046.00035.00)

Parts diagrams

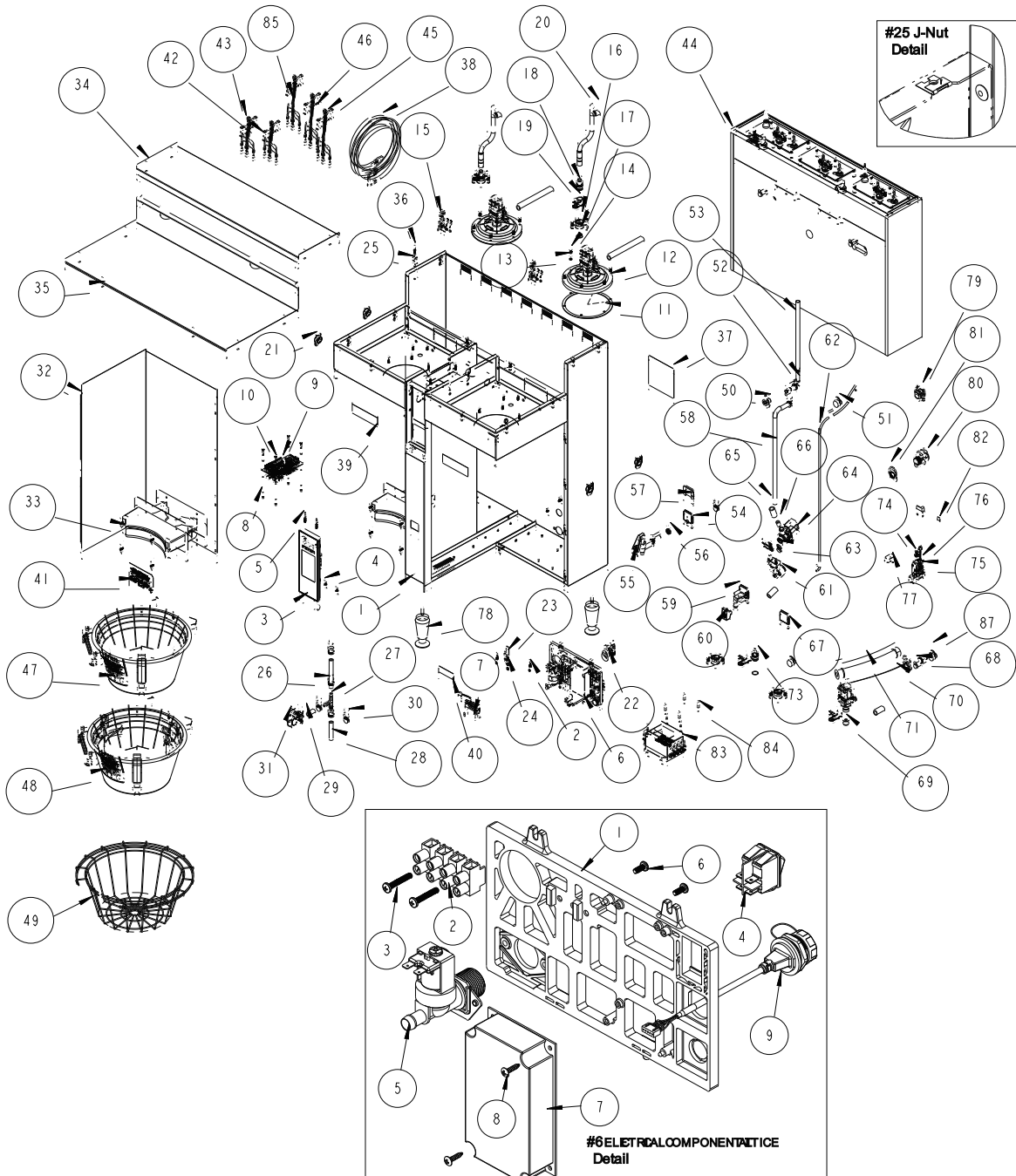

ef	Qty	Part Number	Description
			Drawing 1101.00577.00 CBS-2262
1	1	1111.00109.00	WELDMENT BODY, CBS-2262
2	9	1084.00051.00	NUT, HEX LOCKWASHER, #8-32, 18-8 ST. STL.
3	1	1102.00448.00	FRONT PANEL ASSEMBLY, CBS-2200 SERIES
4	2	1082.00029.00	SCREW, #6 X 3/8 LG, TRUSS HD PHIL, SHEET MTL
5	2	1082.00058.00	SCREW, # 8-32 X 5/8, FLAT HD, PH, 18-8 SS
6 REF	1	Reference	ELECTRICAL COMPONENT LATTICE, NEXT GEN XV+
6-1	1	1023.00350.00	ELECTRICAL MOUNTING LATTICE, COMMON
6-2	1	1052.00023.00	EUROSTRIP HE16 TERM. BLOCK, 4 POLE, 63 AMP, 18-8 AWG
6-3	2	1082.00056.00	SCREW, # 8-16 x 1" PAN HD PHIL, THREAD FORMING, FOR PLASTICS, 18-8 SS
6-4	2	1058.00024.00	SWITCH, POWER, DOUBLE POLE, 16A, 125/250 VAC
6-5	4	1057.00043.00	SOLENOID VALVE, 5.5L/min, 180 DEG, 24VDC
6-6	2	1082.00010.00	SCREW, PAN HD. PHIL. MACH., M4x10 ZINC-PLATED
6-7	1	1052.00059.00	POWER SUPPLY, 90-264VAC/24VDC, 2.25A
6-8	2	1082.00020.00	SCREW, #6 X 5/8, TRUSS HD PHIL, SHEET MTL
7	1	1102.00498.00	VISUAL COMMUNICATION RGB LED BAR ASSY, CBS-2260
8	4	1081.00006.00	SPACER, 6MM OD x 3.2MM ID x 5MM LG, Z/P
9	1	1051.00046.00	CBS-2200 SERIES, I/O BOARD, 24V
10	8	1029.00006.00	NUT, FINGER KNURLED, #4-40
11	2	1024.00113.00	LARGE SPRAYHEAD GASKET
12	2	1102.00482.00	QUICK CONNECT SPRAYHEAD ASSEMBLY, LARGE, RETROFIT

Table continued on the next page

			Table continued from previous page
13	20	1083.00010.00	WASHER, #12 SCREW W/NEOPRENE-BONDED SEAL
14	20	1084.00006.00	NUT, 8-32 18-8 HEX MACHINE SCREW
15	2	1102.00113.00	SWITCH, REED, ASSEMBLY
16	4	1023.00396.00	BASE, QUICK CONNECT BYPASS/VENT, RETROFIT
17	7	1024.00106.00	O-RING, 13/16"OD X 11/16"ID X 1/16" TH, FOR QUICK CONNECT
18	2	1023.00343.00	VENT INSERT, QUICK CONNECT
19	5	1023.00342.00	QUICK CONNECT CLIP
20	2	1024.00098.00	VENT TUBE, CBS- EXTRACTOR SERIES
21	4	1086.00004.00	BUSHING, SNAP, 1" MOUNTING HOLE
22	1	1102.00243.00	ADAPTER ASSY, 3/4" BSP x 1/4" NPT x 3/8" TUBE
23	2	1065.00009.00	GROUND LUG CONNECTOR, 14-2 AWG, ALUMINUM
24	1	1044.00012.00	LABEL GROUND, CE
25	15	1084.00011.00	NUT, CLIP ON (J-NUT), #6-32, 22-20 GA., BLK-PH FINISH
26	1	1025.00100.00	TUBE, 9/16"OD X 5/16"ID X 9"LG
27	1	1029.00002.00	FITTING, HOSE BARB TEE, SIZE 3/8"
28	1	1025.00077.00	TUBE, 9/16"OD X 5/16"ID X 6.50" LG.
29	1	1025.00058.00	TUBE, 9/16"OD X 5/16"ID X 25.00"LG
30	7	1086.00003.00	UNICLAMP, 15.9 HOSE OD CLAMP
31	1	1086.00009.00	CLAMP, 3/4" MAX TUBE OD FLOW CONTROL
32	1	1112.00546.00	WELDMENT FRONT COVER, CBS-2260
33	2	1102.00487.00	ASSEMBLY LOCATOR L4D-15, TPD-30, CBS 12/2260, BLACK
34	1	1001.00445.00	COVER TOP, CBS-2262
35	1	1001.00446.00	COVER, UPPER BASE, CBS-2262
36	23	1082.00017.00	SCREW, TRUSS HD. PHIL. MACHINE, # 6-32 X 1/2 LG.
37	1	1046.00035.00	LABEL, WARNING "TO REDUCE RISK OF ELECTRIC SHOCK OR FIRE"
38	1	1063.00042.00	ETHERNET CABLE, CAT-7, 5FT LENGTH
39	2	1046.00003.00	LABEL, CSD WARNING, 1.5" X 5.0"
40	1	1041.00032.00	BLACK EXTRACTOR NG LABEL, LASER ENGRAVED
41	1	1046.00020.00	TAG, INFORMATION
42	1	1402.00117.10	WIRE HARNESS, CBS-2260, LOW AMP, UNIVERSAL
43	1	1402.00117.11	WIRE HARNES ADDITION, CBS-2262, LOW AMP, UNIVERSAL
44	1	1104.00192.00	TANK ASSEMBLY, CBS-2262, 3 X 3KW/240VAC
		1104.00193.00	TANK ASSEMBLY, CBS-2262, 6 X 3KW/240VAC
		1104.00194.00	TANK ASSEMBLY, CBS-2262, 3 X 4KW/240VAC
		1104.00195.00	TANK ASSEMBLY, CBS-2262, 6 X 4KW/240VAC
		1104.00196.00	TANK ASSEMBLY, CBS-2262, 3 X 5KW/240VAC
45	1	1402.00116.10	WIRE HARNESS, CBS-1262, HIGH AMP, 3 HEATERS, UL
46	1	1402.00116.11	WIRE HARNESS ADDITION, CBS-1262, HIGH AMP, 6(3) HEATERS, UL(CE)
47	2	B00828004	BREW BASKET ASSY, CBS-2060/2160'S Included
48		B00828005	BREW BASKET ASSEMBLY, CBS-2060/2160S, W/CLIPS OPTION-Customer to order
49		B00828005	BREW BASKET INSERT ASSEMBLY, CBS-2060/2160S, 1/2 Batch OPTION-Customer to order
50	1	1024.00111.00	GROMMET, SILICONE, W/ POSITION TABS
51	2	1024.00051.00	GROMMET, SILICONE, BLANK
52	1	1023.00362.00	FITTING VENT, ELBOW, .375" X .375", SELF POSITIONING
53	1	1013.00131.00	TUBE, 304SS, .562OD X .028 WALL X 11-1/2" LG.
54	1	1023.00348.00	HOT WATER INSERT, MANUAL FAUCET
55	1	1071.00055.00	FAUCET, HOT WATER, PSC-BR-8, WITH FLAT AND STEM
56	1	1084.00048.00	JAM NUT, 1/2-20 UNF, NICKEL PLATED BRASS
57	1	1003.00370.00	HOT WATER INSERT LOCK
58	1	1025.00068.00	TUBE, 9/16"OD X 5/16"ID X 21.75"LG
59	1	1023.00346.00	HOT WATER INSERT, AUTO FAUCET
60	1	1029.00041.00	COVER, AUTO HOT WATER FAUCET, SILICONE
61	1	1023.00347.00	VALVE MOUNT, HOT WATER DISPENSER
62	1	1025.00033.00	TUBE, 1/4"OD X 1/8"ID X 35"LG, VENT, HOT WATER VAPOR
63	1	1023.00369.00	ORIFICE INSERT, QUICK CONNECT, 3/16" HOLE
64	2	1057.00076.00	VALVE ASSEMBLY, COMPLETE, NG, DELTROL
65	3	1025.00138.00	TUBE, SILICONE, 3/4" OD X 1/2" ID X 1-1/2" LG, HOT WATER
66	1	1025.00135.00	TUBE, 1/2"OD X 1/4"ID X .75" LG, RESTRICTOR
67	1	1023.00349.00	HOT WATER INSERT, NO FAUCET
68	1	1023.00203.00	FITTING, STRAIGHT, GROMMET, .625"
69	1	1023.00345.00	ORIFICE INSERT, QUICK CONNECT, 5/16" HOLE
70	1	1025.00098.00	TUBE, 5/8"OD X 3/8"ID X 11.25"LG
71	1	1022.00087.00	INSULATION, 5/8" ID X 3/8" TH, 11"LG
72	1	1086.00018.00	CLAMP, HOSE, .875-1.00 DIA. RANGE
73	1	1023.00344.00	PLUG INSERT, QUICK CONNECT
74	2	1102.00445.00	ASSY, BREW BASKET LOCKER W/FEEDBACK
75	6	1083.00009.00	WASHER, #6 SCREW, INTL TOOTH LOCKWASHER
76	2	1084.00010.00	NUT, HEX, #6-32, UNDERSIZED, ZINC PLATED
77	1	1003.00259.00	BRACKET, BREW BASKET LOCK COVER
78	3	1073.00007.00	LEG, FLANGE FOOT, 4" HIGH
79	1	1086.00008.00	CONNECTOR, CLAMP, NON-METALLIC CABLE, 3/4"
80	1	1086.00031.00	SKINTOP, 3/4" NPT, 0.354" - 0.630" DIA CABLE, BLK
81	1	1086.00032.00	LOCKNUT, SKINTOP, 3/4" NPT, BLACK HEX
82	1	1044.00013.00	LABEL EQUIPOTENTIALITY, CE
83	1	1052.00050.00	EMI FILTER, 25A, 250/440VAC, 50/60Hz
84	4	1084.00012.00	NUT, HEX, #6-32 MACHINE SCREW
85	1	1402.00116.12	WIRE HARNESS ADDITION, CBS-1262, HIGH AMP, 3 HEATERS, CE
86	2	1025.00144.00	TUBE, SILICONE, 3/4" OD X 1/2" ID X 6.625" LG, BREW
87	1	1024.00050.00	GROMMET, SILICONE, 11.4mm ID

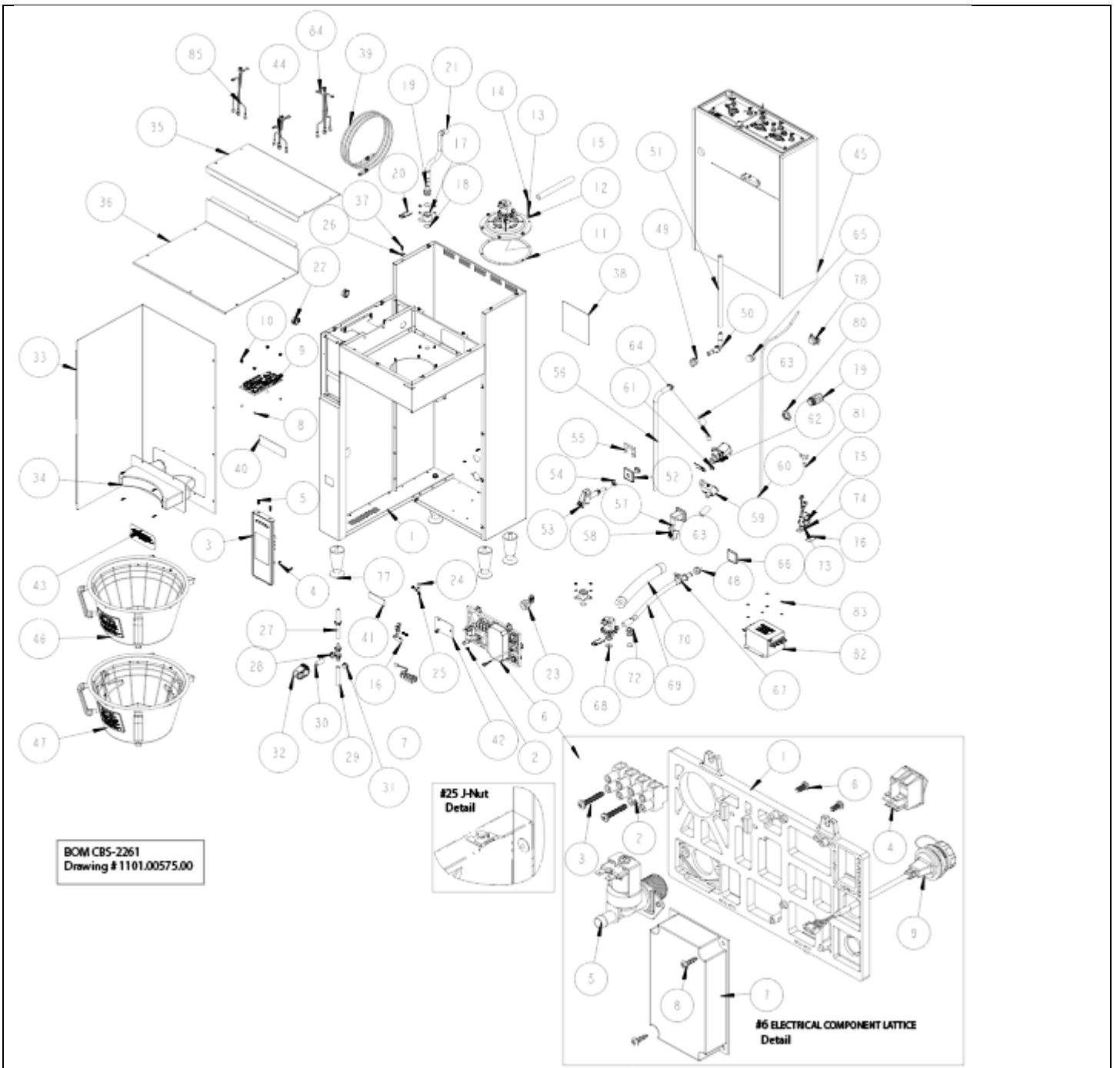

BOM CBS-2261
Drawing #1101.00575.00

Ref	Qty	Part Number	Description	Drawing 1101.00575.00 CBS-2261
1	1	1111.00108.00	WELDMENT BODY, CBS-2261	
2	9	1084.00051.00	NUT, HEX LOCKWASHER, #8-32, 18-8 ST. STL.	
3	1	1102.00448.00	FRONT PANEL ASSEMBLY, CBS-2200 SERIES	
4	2	1082.00029.00	SCREW, #6 X 3/8 LG, TRUSS HD PHIL. SHEET MTL	
5	2	1082.00058.00	SCREW, # 8-32 X 5/8, FLAT HD, PH, 18-8 SS	
6	1	1102.00471.00	ELECTRICAL COMPONENT LATTICE, NEXT GEN XV+ [Purchase repair parts 6-1 to 6-8, below]	
6-1	1	1023.00350.00	ELECTRICAL MOUNTING LATTICE, COMMON	
6-2	1	1052.00023.00	EUROSTRIP HE16 TERM. BLOCK, 4 POLE, 63 AMP, 18-8 AWG	
6-3	2	1082.00139.00	#8-16x1" CROSS RECESS PAN HEAD PLASTIC THREAD SCREW	
6-4	1	1058.00024.00	SWITCH, POWER, DOUBLE POLE, 16A, 125/250 VAC	
6-5	1	1057.00043.00	SOLENOID VALVE, 5.5L/min, 180 DEG, 24VDC	
6-6	2	1082.00010.00	SCREW, PAN HD. PHIL. MACH., M4x10 ZINC-PLATED	
7	1	1102.00498.00	VISUAL COMMUNICATION RGB LED BAR ASSY, CBS-2260	
8	4	1081.00006.00	SPACER, 6MM OD x 3.2MM ID x 5MM LG, Z/P	
9	1	1108.00064.00	PCB AND SOFTWARE, ASSY, CBS-2200NG I/O Board	
10	6	1029.00006.00	NUT, FINGER KNURLED, #4-40	
11	1	1024.00113.00	LARGE SPRAYHEAD GASKET	
12	1	1102.00482.00	QUICK CONNECT SRAYHEAD ASSEMBLY, LARGE, RETROFIT	
Parts list continues next page				

Ref	Qty	Part Number	Description	Drawing 1101.00575.00 CBS-2261 ...Continued from page 19
13	10	1083.00010.00	WASHER, #12 SCREW W/NEOPRENE-BONDED SEAL	
14	10	1084.00006.00	NUT, 8-32 18-8 HEX MACHINE SCREW	
15	1	1025.00144.00	TUBE, SILICONE, 3/4" OD X 1/2" ID X 6.625" LG, BREW	
16	1	1102.00113.00	SWITCH, REED, ASSEMBLY	
17	2	1023.00396.00	BASE, QUICK CONNECT BYPASS/VENT, RETROFIT	
18	4	1024.00106.00	O-RING, 13/16"OD X 11/16"ID X 1/16" TH, FOR QUICK CONNECT	
19	1	1023.00343.00	VENT INSERT, QUICK CONNECT	
20	3	1023.00342.00	QUICK CONNECT CLIP	
21	1	1024.00098.00	VENT TUBE, CBS- EXTRACTOR SERIES	
22	2	1086.00004.00	BUSHING, SNAP, 1" MOUNTING HOLE	
23	1	1102.00243.00	ADAPTER ASSY, 3/4" BSP x 1/4" NPT x 3/8" TUBE	
24	2	1065.00009.00	GROUND LUG CONNECTOR, 14-2 AWG, ALUMINUM	
25	1	1044.00012.00	LABEL GROUND, CE	
26	14	1084.00011.00	NUT, CLIP ON (J-NUT), #6-32, 22-20 GA., BLK-PH FINISH	
27	1	1025.00100.00	TUBE, 9/16"OD X 5/16"ID X 9"LG	
28	1	1029.00002.00	FITTING, HOSE BARB TEE, SIZE 3/8"	
29	1	1025.00077.00	TUBE, 9/16"OD X 5/16"ID X 6.50" LG.	
30	1	1025.00058.00	TUBE, 9/16"OD X 5/16"ID X 25.00"LG	
31	1	1086.00003.00	UNICLAMP, 15.9 HOSE OD CLAMP	
32	1	1086.00009.00	CLAMP, 3/4" MAX TUBE OD FLOW CONTROL	
33	1	1112.00546.00	WELDMENT FRONT COVER, CBS-2260	
34	1	1102.00487.00	ASSEMBLY LOCATOR L4D-15, TPD-30, CBS 12/2260, BLACK	
35	1	1001.00439.00	COVER TOP, CBS-2261	
36	1	1001.00440.00	COVER, UPPER BASE, CBS-2261	
37	18	1082.00017.00	SCREW, TRUSS HD. PHIL. MACHINE, # 6-32 X 1/2 LG.	
38	1	1046.00035.00	LABEL, WARNING "TO REDUCE RISK OF ELECTRIC SHOCK OR FIRE"	
39	1	1063.00042.00	ETHERNET CABLE, CAT-7, 5FT LENGTH	
40	1	1046.00003.00	LABEL, CSD WARNING, 1.5" X 5.0"	
41	1	1041.00032.00	BLACK EXTRACTOR NG LABEL, LASER ENGRAVED	
42	1	1044.00006.00	CARD, SINGLE OR THREE PHASE JUMPER INSTRUCTION	
43	1	1046.00020.00	TAG, INFORMATION	
44	1	1402.00117.10 L	WIRE HARNESS, CBS-2260, LOW AMP, UNIVERSA	
45	1	1104.00199.00	TANK ASSEMBLY, CBS-2261, 3 X 3KW/240VAC	
45	1	1104.00200.00	TANKASSEMBLY,CBS-2261,3X4KW/240VAC	
45	1	1104.00201.00	TANKASSEMBLY,CBS-2261,3X5KW/240VAC	
46	1	B00828004	BREW BASKET ASSY, CBS-2060/2160'S	
		B00828005	BREW BASKET ASSY, CBS-2160'S, W/ CLIPS OPTIONAL-Customer purchase (see CBS-2262 ill)	
		1009.00009.00	1/2 BATCH BREW BASKET, INSERT ONLY, OPTIONAL-Customer purchase (see CBS-2262 ill)	
47	1	1024.00050.00	GROMMET, SILICONE, 11.4mm ID	
48	1	1024.00111.00	GROMMET, SILICONE, W/ POSITION TABS	
49	1	1023.00362.00	FITTING VENT, ELBOW, .375" X .375", SELF POSITIONING	
50	1	1013.00131.00	TUBE, 304SS, .562OD X .028 WALL X 11-1/2" LG.	
51	1	1023.00348.00	HOT WATER INSERT, MANUAL FAUCET	
52	1	1071.00055.00	FAUCET, HOT WATER, PSC-BR-8, WITH FLAT AND STEM	
53	1	1084.00048.00	JAM NUT, 1/2-20 UNF, NICKEL PLATED BRASS	
54	1	1003.00370.00	HOT WATER INSERT LOCK	
55	1	1025.00068.00	TUBE, 9/16"OD X 5/16"ID X 21.75"LG	
56	1	1023.00346.00	HOT WATER INSERT, AUTO FAUCET	
57	1	1029.00041.00	COVER, AUTO HOT WATER FAUCET, SILICONE	
58	1	1023.00347.00	VALVE MOUNT, HOT WATER DISPENSER	
59	1	1025.00033.00	TUBE, 1/4"OD X 1/8"ID X 35"LG, VENT, HOT WATER VAPOR	
60	1	1023.00369.00	ORIFICE INSERT, QUICK CONNECT, 3/16" HOLE	
61	2	1057.00076.00	VALVE ASSEMBLY, COMPLETE, NG, DELTROL	
62	3	1025.00138.00	TUBE, SILICONE, 3/4" OD X 1/2" ID X 1-1/2" LG, HOT WATER	
63	1	1025.00135.00	TUBE, 1/2"OD X 1/4"ID X .75" LG, RESTRICTOR	
64	1	1024.00051.00	GROMMET, SILICONE, BLANK	
65	1	1023.00349.00	HOT WATER INSERT, NO FAUCET	
66	1	1023.00203.00	FITTING, STRAIGHT, GROMMET, .625"	
67	1	1023.00345.00	ORIFICE INSERT, QUICK CONNECT, 5/16" HOLE	
68	1	1025.00098.00	TUBE, 5/8"OD X 3/8"ID X 11.25"LG	
69	1	1022.00087.00	INSULATION, 5/8" ID X 3/8" TH, 11"LG	
70	1	1086.00018.00	CLAMP, HOSE, .875-1.00 DIA. RANGE	
71	1	1023.00344.00	PLUG INSERT, QUICK CONNECT	
72	1	1102.00445.00	ASSY, BREW BASKET LOCKER W/FEEDBACK	
73	6	1083.00009.00	WASHER, #6 SCREW, INTL TOOTH LOCKWASHER	
74	2	1084.00010.00	NUT, HEX, #6-32, UNDERSIZED, ZINC PLATED	
75	1	1003.00259.00	BRACKET, BREW BASKET LOCK COVER	
76	4	1073.00007.00	LEG, FLANGE FOOT, 4" HIGH	
77	1	1086.00008.00	CONNECTOR, CLAMP, NON-METALLIC CABLE, 3/4"	
78	1	1086.00031.00	SKINTOP, 3/4" NPT, 0.354" - 0.630" DIA CABLE, BLK	
79	1	1086.00032.00	LOCKNUT, SKINTOP, 3/4" NPT, BLACK HEX	
80	1	1044.00013.00	LABEL EQUIPOTENTIALITY, CE	
81	1	1052.00050.00	EMI FILTER, 25A, 250/440VAC, 50/60Hz	
82	4	1084.00012.00	NUT, HEX, #6-32 MACHINE SCREW	
83	1	1402.00112.10	WIRE HARNESS, CBS-1252/61, HIGH AMP, 1 OR 3PH, 3 HEATERS, UL	
84	1	1402.00120.10	HARNESS, CBS-1252/61, 3 H, H AMP, 3L-N-PE, 220/380-240/415VAC	

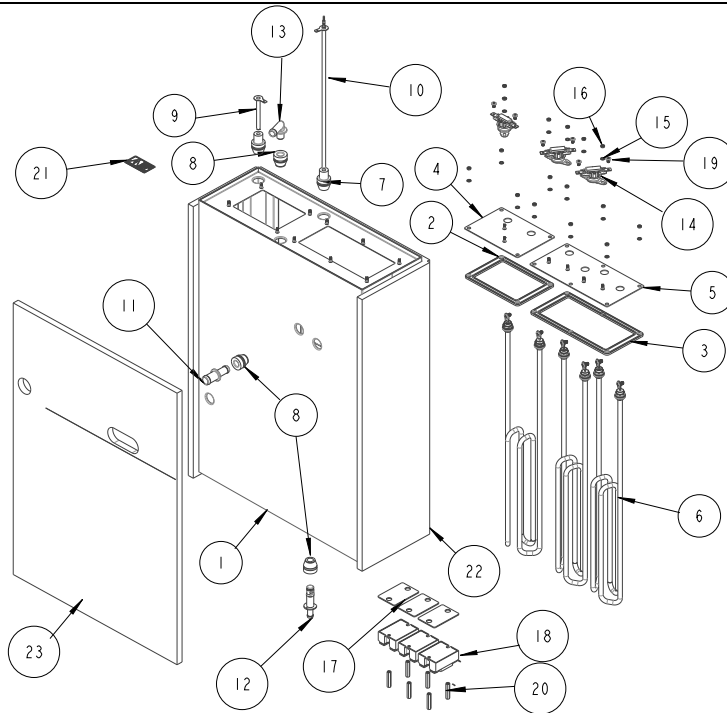

CBS-2261 Hot Water Tank three heater drawings 1104.00199.00, 1104.00200.00, 1104.00201.00

#	QTY	PART NO	DESCRIPTION
1	1	1114.00174.00	WELDMENT TANK, CBS-2261. LASER
2	1	1024.00115.00	TANK GASKET - NG HEATER PLATE, ONE ELEMENT
3	1	1024.00114.00	TANK GASKET - NG HEATER PLATE, TWO ELEMENT
4	1	1114.00181.00	WELDMENT TANK HEATER BRACKET, NG-2232
5	1	1114.00176.00	WELDMENT TANK HEATER BRACKET, NG-2231
6	3	1107.00005.00	HEATER ASSEMBLY, IMMERSION 3kW/240VAC
6	3	1107.00010.00	HEATER ASSEMBLY, IMMERSION 4kW/240VAC
6	3	1107.00032.00	HEATER ASSEMBLY, IMMERSION 5kW/240VAC
7	2	1024.00053.00	LEVEL AND TEMP PROBE GROMMET
8	3	1024.00050.00	GROMMET, SILICONE, 11.4mm ID
9	1	1112.00019.00	PROBE WELDMENT, WATER LEVEL 2.600" LG
10	1	1102.00234.00	PROBE ASSEMBLY, TEMP. AND LLC 12" LONG
11	1	1023.00203.00	FITTING, STRAIGHT, GROMMET, .625"
12	1	1023.00166.00	FITTING, COLD WATER INLET, GROMMET DESIGN
13	1	1023.00212.00	FITTING, ELBOW, GROMMET, .500"
14	3	1053.00052.00	THERMOSTAT, SINGLE SHOT, SCREW CONNECTIONS, 240V/25A,
15	16	1083.00009.00	WASHER, #6 SCREW , INTL TOOTH LOCKWASHER
16	16	1084.00010.00	NUT, HEX, #6-32, UNDERSIZED, ZINC PLATED
17	3	1003.00140.00	ALUMINUM BRACKET FOR SSR
18	3	1052.00033.00	RELAY, SOLID STATE, 50A/480VAC, W/BUILD IN VARISTOR
19	6	1082.00136.00	BRASS SCREW, #8-32 X 1/4", PHILLIPS PAN HEAD
20	6	1081.00042.00	STANDOFF, 1/4" HEX
21	1	1044.00004.00	LABEL, DANGER, HIGH VOLTAGE
22	1	1022.00040.00	INSULATION, TANK, BACK, CBS-2061E
23	1	1022.00090.00	INSULATION TANK FRONT, CBS-2161 XTS

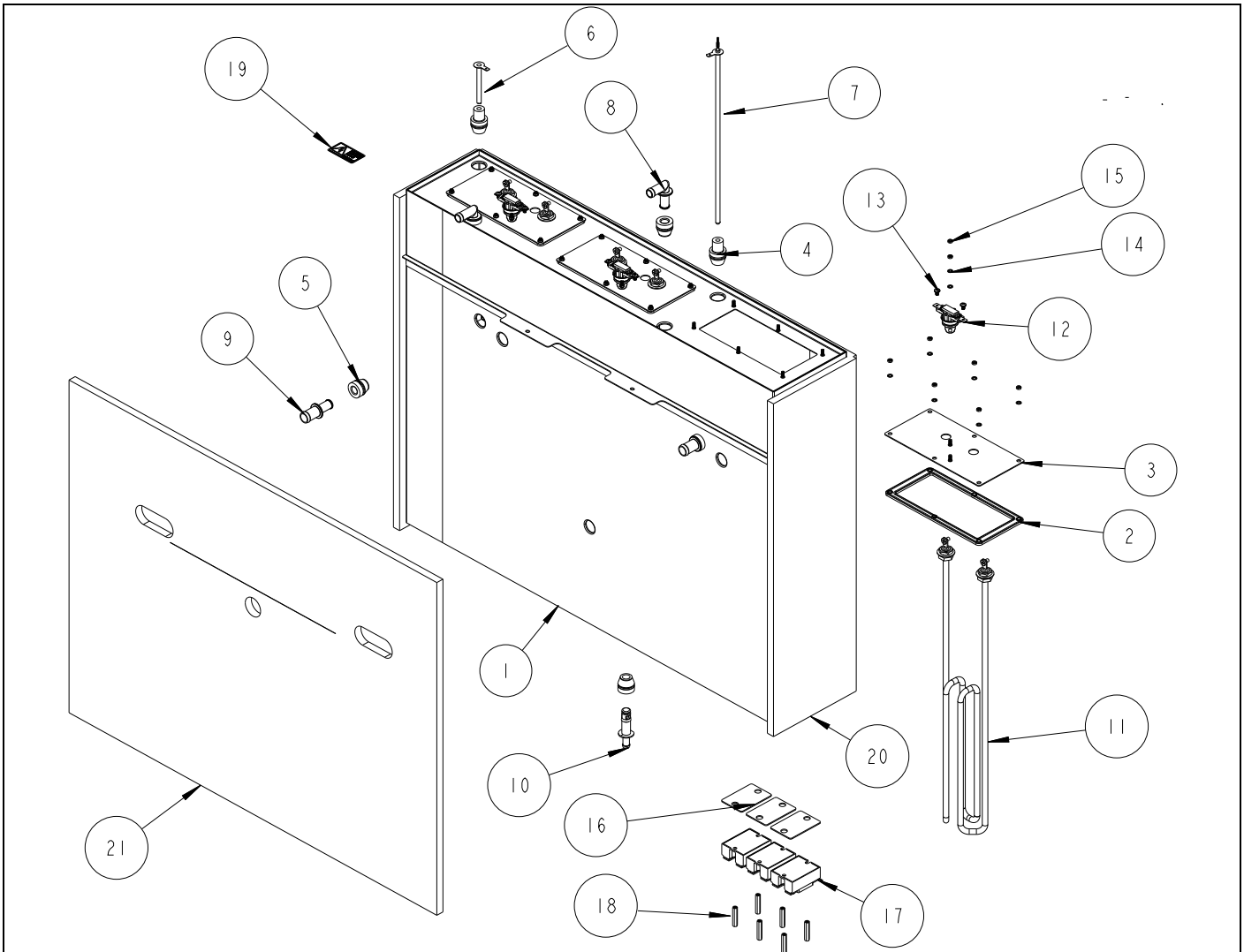

CBS-2262 Hot Water Tank three heater drawings 1104.00192.00, 1104.00194.00, 1104.00196.00

#	QTY	PART NO	DESCRIPTION
1	1	1114.00175.00	WELDMENT, TANK, CBS-12/2262
2	3	1024.00114.00	TANK GASKET - NG HEATER PLATE, TWO ELEMENT
3	3	1114.00184.00	WELDMENT TANK HEATER BRACKET, NG-LARGE, TWO HEATER
4	2	1024.00053.00	LEVEL AND TEMP PROBE GROMMET
5	5	1024.00050.00	GROMMET, SILICONE, 11.4mm ID
6	1	1112.00019.00	PROBE WELDMENT, WATER LEVEL 2.600" LG
7	1	1102.00234.00	PROBE ASSEMBLY, TEMP. AND LLC 12" LONG
8	2	1023.00212.00	FITTING, ELBOW, GROMMET, .500"
9	2	1023.00203.00	FITTING, STRAIGHT, GROMMET, .625"
10	1	1023.00166.00	FITTING, COLD WATER INLET, GROMMET DESIGN
11	3	1107.00005.00	HEATER ASSEMBLY, IMMERSION 3kW/240VAC
11	3	1107.00010.00	HEATER ASSEMBLY, IMMERSION 4kW/240VAC
11	3	1107.00032.00	HEATER ASSEMBLY, IMMERSION 5kW/240VAC
12	3	1053.00052.00	THERMOSTAT, SINGLE SHOT, SCREW CONNECTIONS, 240V/25A
13	6	1082.00136.00	BRASS SCREW, #8-32 X 1/4", PHILLIPS PAN HEAD
14	24	1083.00009.00	WASHER, #6 SCREW, INTL TOOTH LOCKWASHER
15	24	1084.00010.00	NUT, HEX, #6-32, UNDERSIZED, ZINC PLATED
16	3	1003.00140.00	ALUMINUM BRACKET FOR SSR
17	3	1052.00033.00	RELAY, SOLID STATE, 50A/480VAC, W/BUILD IN VARISTOR
18	6	1081.00042.00	STANDOFF, 1/4" HEX
19	1	1044.00004.00	LABEL, DANGER, HIGH VOLTAGE
20	1	1022.00033.00	INSULATION, TANK, BACK, CBS-2062e
21	1	1022.00086.00	INSULATION TANK FRONT, CBS-2162 XTS

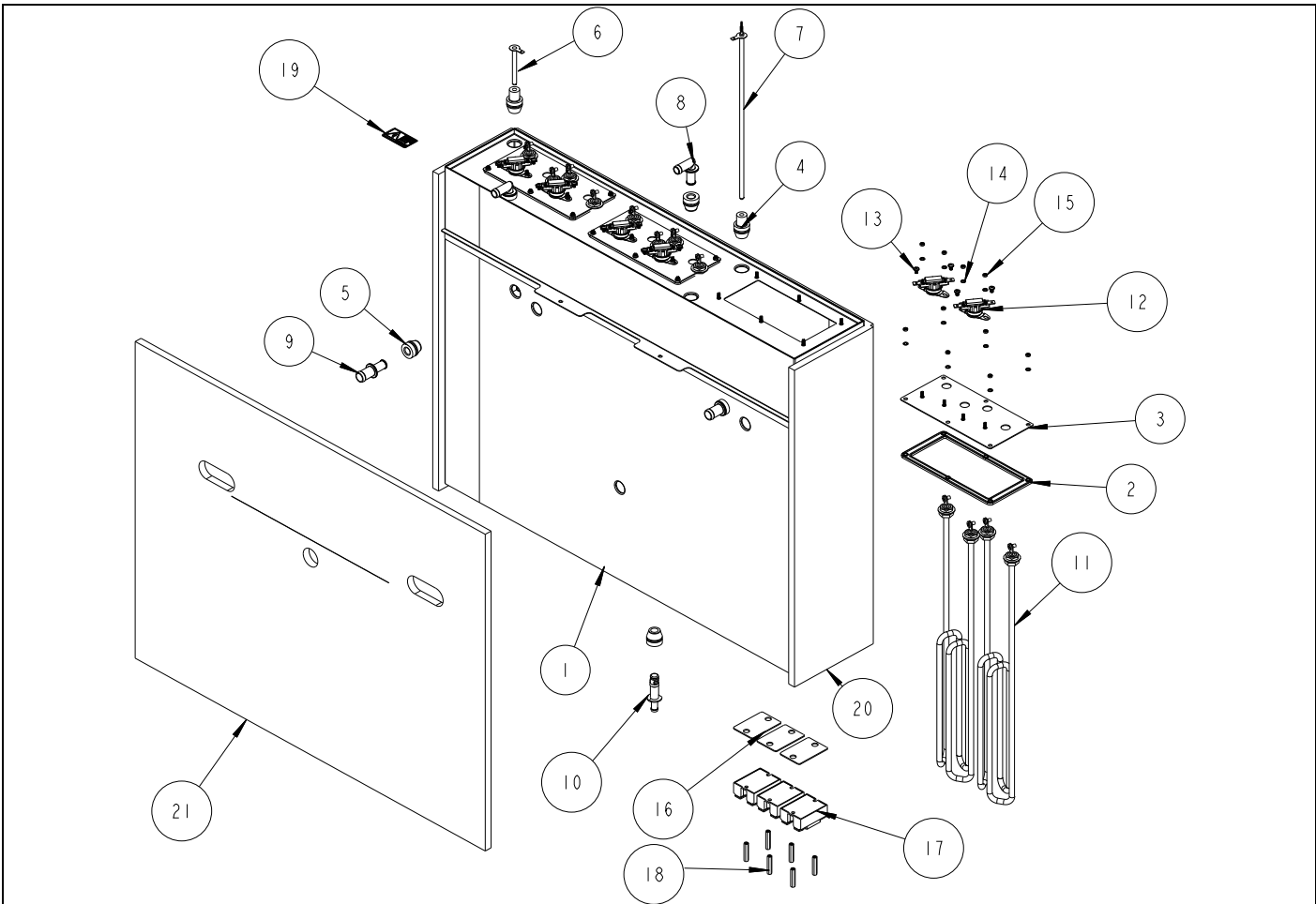

CBS-2262 Hot Water Tank six heater drawings 1104.00193.00, 1104.00195.00, 1104.001976.00

#	QTY	PART NO	DESCRIPTION
1	1	1114.00175.00	WELDMENT, TANK, CBS-12/2262
2	3	1024.00114.00	TANK GASKET - NG HEATER PLATE, TWO ELEMENT
3	3	1114.00176.00	WELDMENT TANK HEATER BRACKET, NG-LARGE, ONE HEATER
4	2	1024.00053.00	LEVEL AND TEMP PROBE GROMMET
5	5	1024.00050.00	GROMMET, SILICONE, 11.4mm ID
6	1	1112.00019.00	PROBE WELDMENT, WATER LEVEL 2.600" LG
7	1	1102.00234.00	PROBE ASSEMBLY, TEMP. AND LLC 12" LONG
8	2	1023.00212.00	FITTING, ELBOW, GROMMET, .500"
9	2	1023.00203.00	FITTING, STRAIGHT, GROMMET, .625"
10	1	1023.00166.00	FITTING, COLD WATER INLET, GROMMET DESIGN
11	6	1107.00005.00	HEATER ASSEMBLY, IMMERSION 3kW/240VAC
11	6	1107.00010.00	HEATER ASSEMBLY, IMMERSION 4kW/240VAC
11	6	1107.00032.00	HEATER ASSEMBLY, IMMERSION 5kW/240VAC
12	6	1053.00052.00	THERMOSTAT, SINGLE SHOT, SCREW CONNECTIONS, 240V/25A
13	12	1082.00136.00	BRASS SCREW, #8-32 X 1/4", PHILLIPS PAN HEAD
14	30	1083.00009.00	WASHER, #6 SCREW, INTL TOOTH LOCKWASHER
15	30	1084.00010.00	NUT, HEX, #6-32, UNDERSIZED, ZINC PLATED
16	3	1003.00140.00	ALUMINUM BRACKET FOR SSR
17	3	1052.00033.00	RELAY, SOLID STATE, 50A/480VAC, W/BUILD IN VARISTOR
18	6	1081.00042.00	STANDOFF, 1/4" HEX
19	1	1044.00004.00	LABEL, DANGER, HIGH VOLTAGE
20	1	1022.00033.00	INSULATION, TANK, BACK, CBS-2062e
21	1	1022.00086.00	INSULATION TANK FRONT, CBS-2162 XTS

Modular Brew Head and Bypass Valves

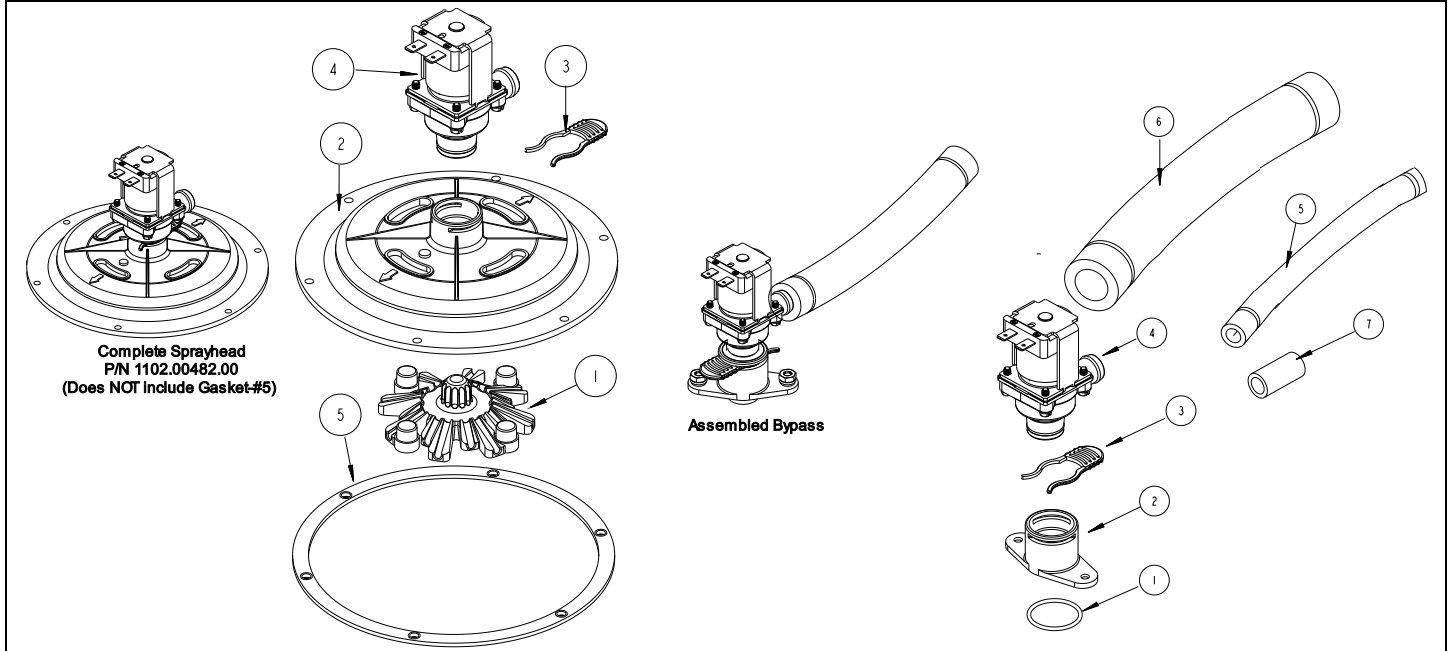

Modular Spray Head

#	QTY	PART NO	DESCRIPTION
1	1	1102.00043.00	CASCADE SPRAY DOME, CBS-2050/60'S
2	1	1000.00145.00	QUICK CONNECT LARGE SPRAYHEAD, MODULE
3	1	1023.00342.00	QUICK CONNECT CLIP
4	1	1057.00076.00	VALVE ASSEMBLY, COMPLETE, NG, DELTROL
5	1	1024.00113.00	LARGE SPRAYHEAD GASKET

Modular Bypass Valve

#	QTY	PART NO	DESCRIPTION
1	1	1024.00002.00	O RING, 15/16 X 1/16 CS, DASH #019
2	1	1023.00396.00	BASE, QUICK CONNECT BYPASS/VENT, RETROFIT
3	1	1023.00342.00	QUICK CONNECT CLIP
4	1	1057.00076.00	VALVE ASSEMBLY, COMPLETE, NG, DELTROL
5	1	1025.00098.00	TUBE, 5/8"OD X 3/8"ID X 11.25"L
6	1	1022.00087.00	INSULATION, 5/8" ID X 3/8" TH, 11"LG
7	1	1025.00138.00	TUBE, SILICONE, 3/4" OD X 1/2" ID X 1-1/2" LG, HOT WATER

Brew Baskets

	Ref#	Part Number	Description
		B00828004	Complete Stainless Steel Brew basket <u>no clips</u>
	←	B00828005	Complete Stainless Steel Brew basket <u>with clips</u>
	1	1112.00116.00	WELDMENT, BREW BASKET, CBS-60'S
	2	1046.00015.00	LABEL, CAUTION, BREW BASKET, CBS-60'S
	3	1009.00004.00	BASKET, WIRE, 21"X7", CBS-60'S
	4	1102.00154.00	HOUSING ASSEMBLY, BREW BASKET MAGNET, CBS-2060'S
	5	1082.00072.00	SCREW, 10-16 x 1/2", 410 SS, PAN HD PH., T/F
	6	1000.00053.00	CLIP KIT, CBS-60'S

FETCO® **PART # K053 – BREW BASKET CLIPS**
 For part # 101050 brew basket, 21" X 7", used on models CBS-61H & 62H
 Includes 2 – brew basket clips with support brackets.

INSTALLATION INSTRUCTIONS

- Place the open ends of the support bracket under the four horizontal wires near the top of the brew basket wire insert.
 Press the bracket up as far as it will go until the assembly is firmly attached as shown.
- Attach the second clip assembly directly opposite the first clip assembly.
- The completed assembly should look like this:

Example of instructions from CBS-2260 brew basket clip installation.

Clip kit shown in table above

Wiring Diagrams

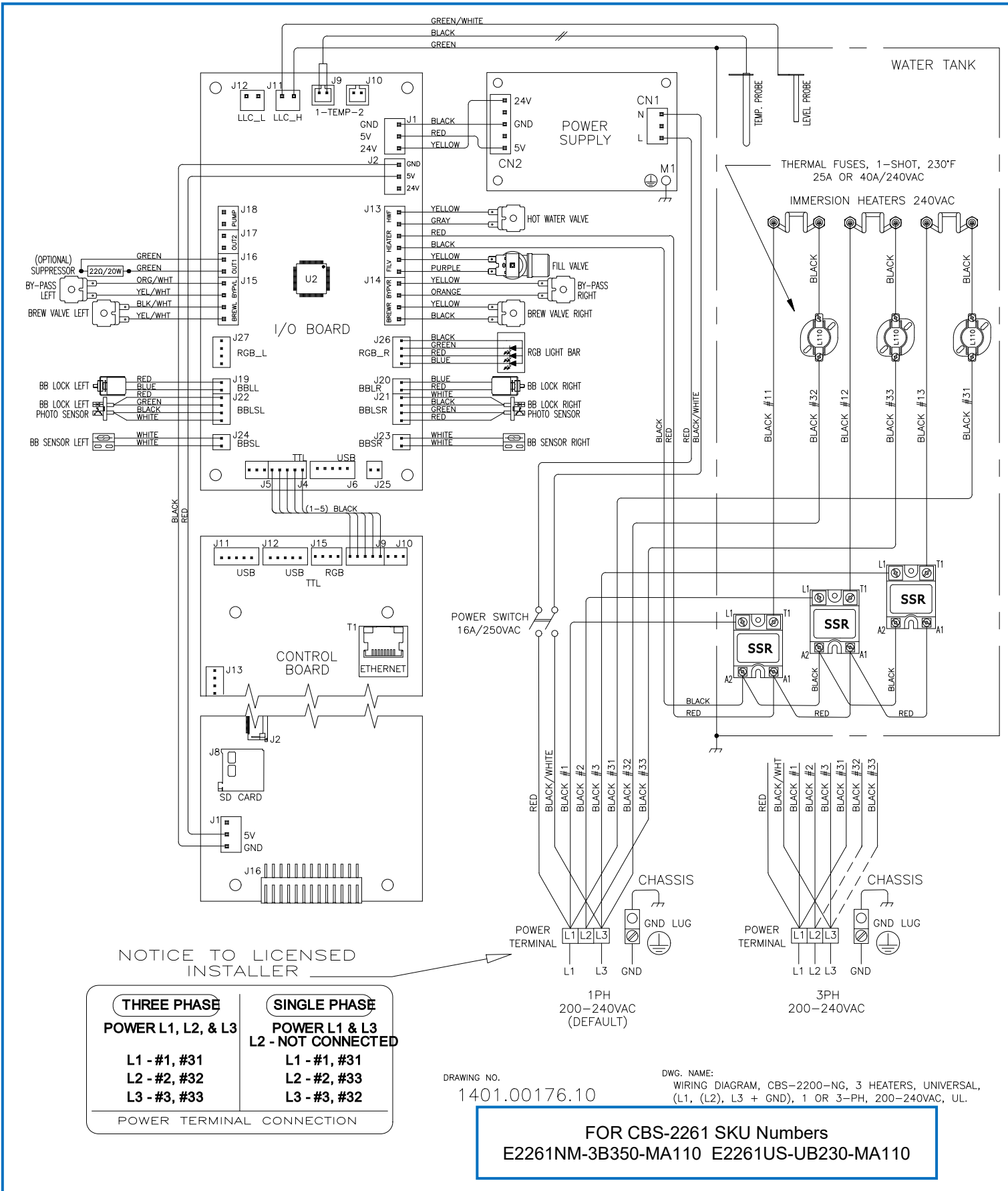

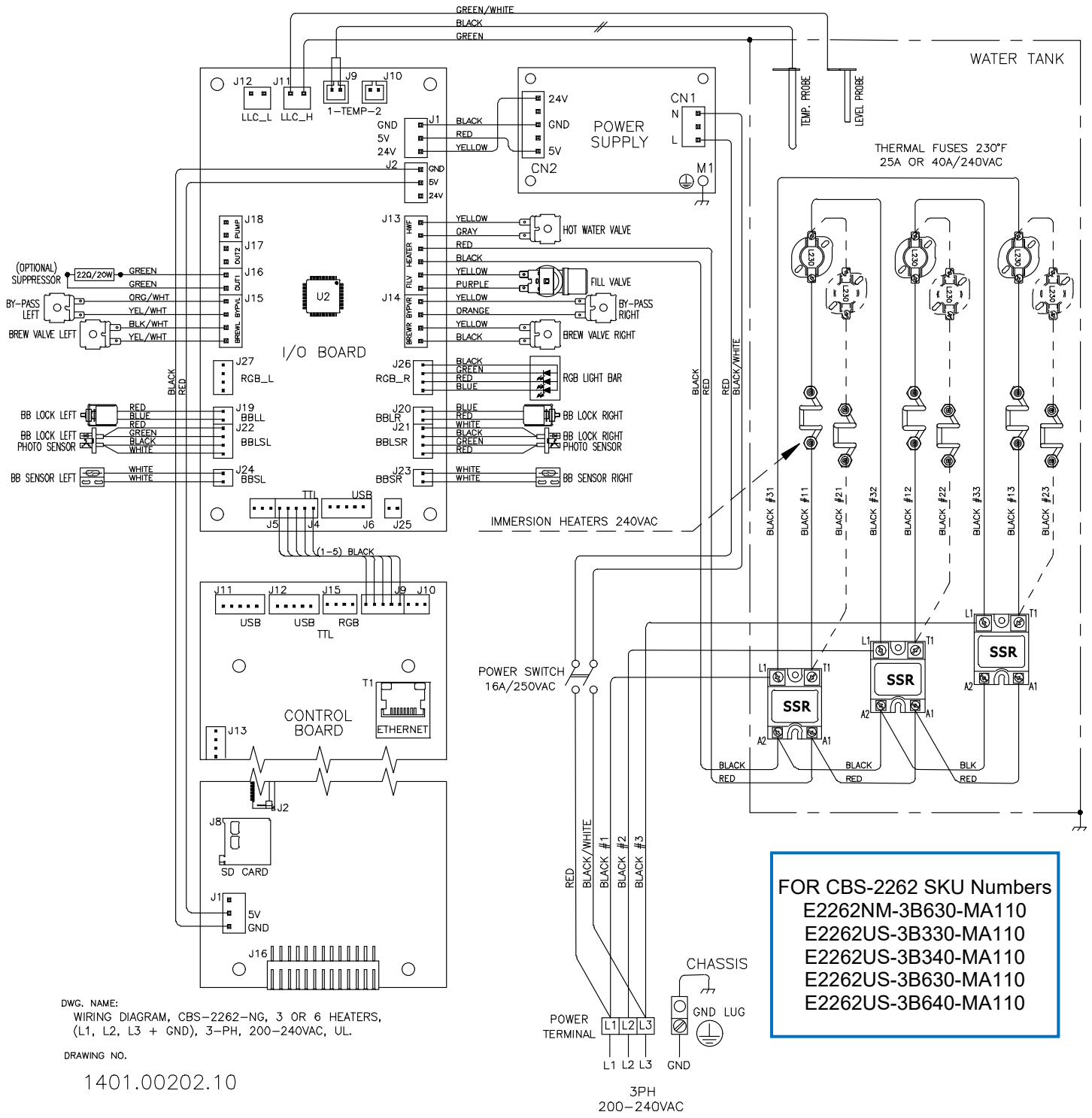

DWG. NAME:
 WIRING DIAGRAM, CBS-2262-NG, 3 OR 6 HEATERS,
 (L1, L2, L3 + GND), 3-PH, 200-240VAC, UL.

DRAWING NO.

1401.00202.10